

MAXPAX

CATALOGUE

TAIWAN STRAPPING MACHINE

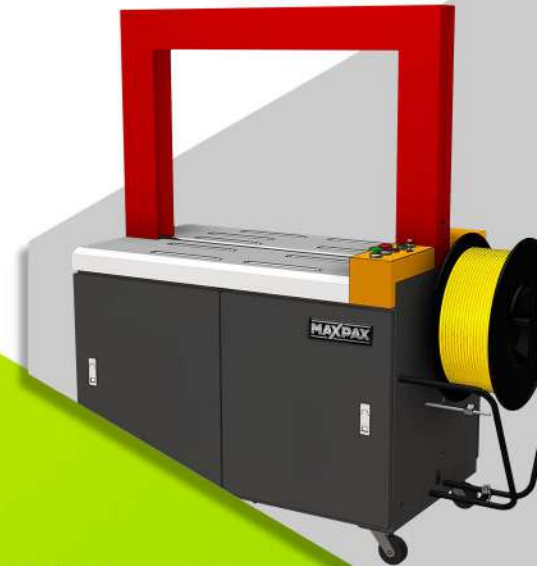

JAKARTA

Jalan Gunung Sahari XI No. 76A

021 623 20 700

jakarta@wiratech.co.id

SURABAYA

Jalan Bubutan 79

031 545 88 53

surabaya@wiratech.co.id

WIRATECH.CO.ID

Strapping Heads

Fully Automatic Machine Series:

Unique Feeding and Reversing Strapping System.

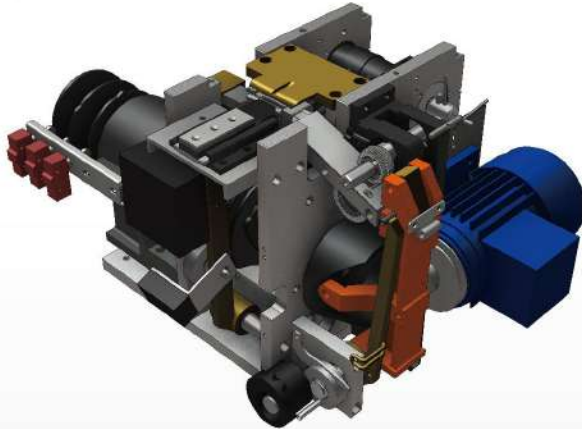

DUAT Series:

The DUAT strapping head is equipped with brushless DC motors to achieve high speed strapping performance. Moreover, it requires low maintenance.

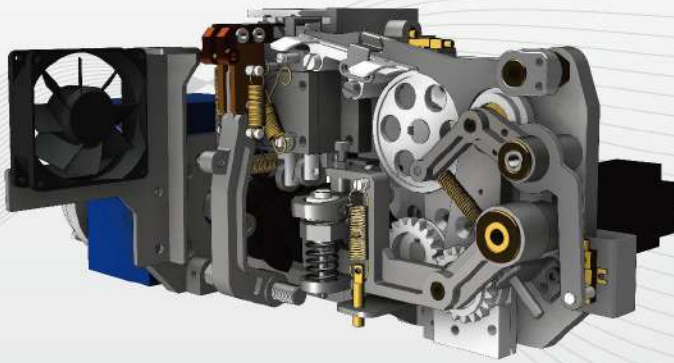

U Series:

Maximum Strap Tension Force up to 400 Kgs (Base on 19mm PET)

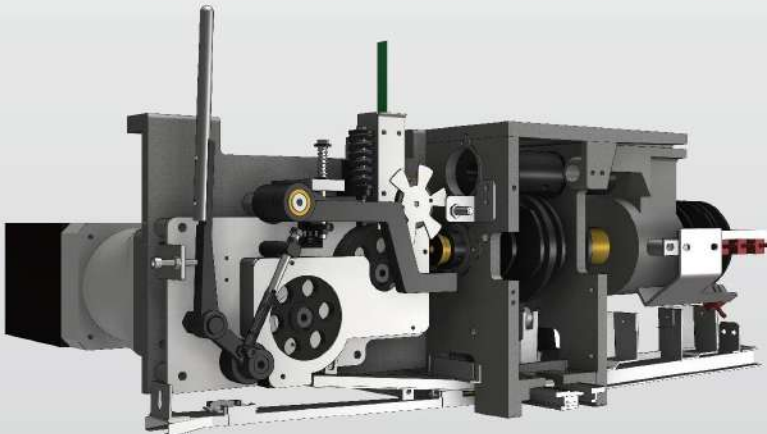

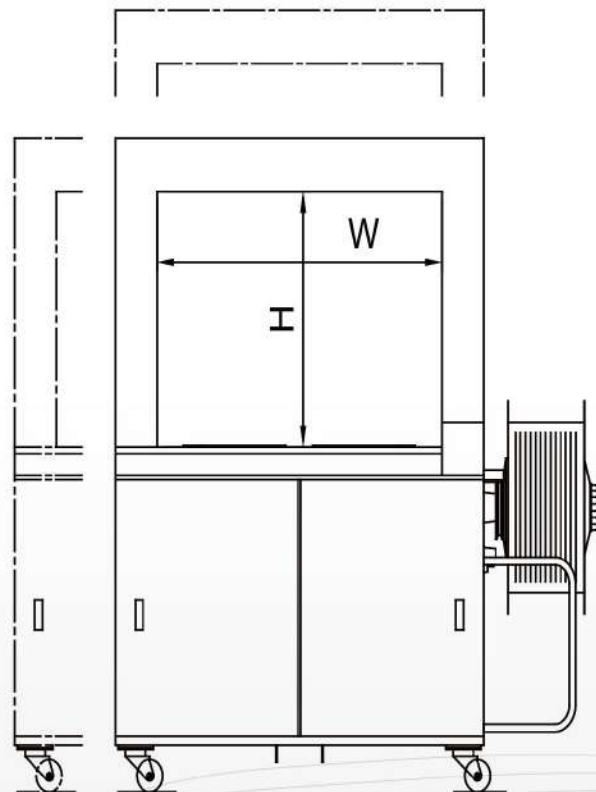

Steel Arch



Aluminum Arch



Height (H) added sections

Standard height (600m/m)

Standard width (850m/m)

Width (W) added sections (one section is 200m/m)

Available Sizes of Arch

H \ W	650	850	1050	1250	1450	1650	1850	2050
400	*	*	*	*	*	*	☆	☆
600	*	S	*	*	*	*	☆	☆
800	*	*	*	*	*	☆	☆	☆
1000	*	*	*	*	☆	☆	☆	☆
1200	*	*	*	☆	☆	☆	☆	☆
1400	*	*	☆	☆	☆	☆	☆	☆
1600	☆	☆	☆	☆	☆	☆	☆	☆
1800	☆	☆	☆	☆	☆	☆	☆	☆
2000	☆	☆	☆	☆	☆	☆	☆	☆
2200	☆	☆	☆	☆	☆	☆	☆	☆
2400	☆	☆	☆	☆	☆	☆	☆	☆
.....	☆	☆	☆	☆	☆	☆	☆	☆

S :The standard model * :Made by order production

☆:Made by order production. The arch motor is required

Semi Automatic Models



PW-316H

Options

- Outside tension
- Air filter
- Stainless steel structure SUS #304
- Casters with brake



PW-616H

PW-316H / PW-616H Semi-automatic Strapping Machine

Mechanical Tension Adjustment

H:High Profile

Power	1Ø, 110/220V, 50/60Hz
Strap Width	9, 12, 15 mm (adjustable) (6mm option)
Strapping Tension	15 ~ 50 Kgs
Strapping Speed	2.0 sec./strap
Strapping Size	Min. : 60 mm, Max. : Any size
PW-316H Table Height	750 mm
PW-616H Table Height	750 ~ 890 mm (Adjustable)
Machine Size	L 910 x W 580 x H 750 mm



PW-320H

Options

- Air filter
- Stainless steel structure SUS #304
- Casters with brake



PW-620H

PW-320H / PW620H Semi-automatic Strapping Machine

Electronic Tension Adjustment

H:High Profile

Power	1Ø, 110/220V, 50/60Hz
Strap Width	9, 12, 15 mm (adjustable) (6mm option)
Strapping Tension	5 ~ 50 Kgs
Strapping Speed	2.0 sec./strap
Strapping Size	Min. : 60 mm, Max. : Any size
PW-320H Table Height	750 mm
PW-620H Table Height	750 ~ 890 mm (Adjustable)
Machine Size	L 910 x W 580 x H 750 mm



PW-216M

Options

- Air filter



PW-216H

PW-216M / PW216H Semi-automatic Strapping Machine

Mechanical Tension Adjustment

M: Mini Type / H:High Profile

Power	1Ø, 110/220V, 50/60Hz
Strap Width	9, 12, 15 mm (adjustable) (6mm option)
Strapping Tension	15 ~ 50 Kgs
Strapping Speed	2.0 sec./strap
Strapping Size	Min. : 60 mm, Max. : Any size
PW-216M Table Height	250 mm
PW-216H Table Height	770 mm
PW-216M Machine Size	L 890 x W 425 x H 250 mm
PW-216H Machine Size	L 650 x W 420 x H 770 mm



PW-220M

Options

- Air filter



PW-220H

PW-220M / PW220H Semi-automatic Strapping Machine

Electronic Tension Adjustment

M: Mini Type / H:High Profile

Power	1Ø, 110/220V, 50/60Hz
Strap Width	9, 12, 15 mm (adjustable) (6mm option)
Strapping Tension	5 ~ 50 Kgs
Strapping Speed	2.0 sec./strap
Strapping Size	Min. : 60 mm, Max. : Any size
PW-220M Table Height	250 mm
PW-220H Table Height	800 mm
PW-220M Machine Size	L 920 x W 480 x H 250 mm
PW-220H Machine Size	L 660 x W 480 x H 800 mm

Semi Automatic Side Seal Models



PW-716Y

PW-716Y Semi-automatic Strapping Machine

Y: Side Seal

Power	1Ø, 110/220V, 50/60Hz
Strap Width	9, 12, 15 mm (adjustable) (6mm option)
Strapping Tension	15 ~ 50 Kgs
Strapping Speed	2.0 sec./strap
Strapping Size	Min. : 60 mm, Max. : Any size
Table Height	502 ~ 852 mm (Adjustable)
Machine Size	L 1230 x W 680 x H 1662 mm

Options

- Stainless steel structure SUS #304



PW-717Y

PW-717Y Semi-automatic Strapping Machine

Side Seal Model – Table Height Adjusted by Handling Bar

Power	1Ø, 110/220V, 50/60Hz
Strap Width	9, 12, 15 mm (adjustable) (6mm option)
Strapping Tension	15 ~ 50 Kgs
Strapping Speed	2.0 sec./strap
Strapping Size	Min. : 60 mm, Max. : Any size
Table Height	502 ~ 852 mm (Adjustable)
Machine Size	L 1230 x W 680 x H 1662 mm

Options

- Stainless steel structure SUS #304

Dispenser Models



P200

P200 For PP/PET Strap Dispenser

For PP/PET Strap Dispenser

Inside Core Diameter	200 mm (7.9")
Outside Core Diameter	480 mm (18.9")
Machine Size	L 500 x W 490 x H 1012 mm
Packing Size	L 720 W 520 x H 455 mm



P400

P400 For PP/PET/Steel Strap Dispenser

For PP/PET Strap Dispenser

Inside Core Diameter	406 mm (16")
Outside Core Diameter	650 mm (25.6")
Machine Size	L 650 x W 432 x H 1012 mm
Packing Size	L 770 x W 710 x H 490 mm



S101

S101 /S102 For Steel Strap Dispenser

For Steel Strap Dispenser

Diameter	600 mm (23.6")
Strap Width	15 ~ 19 mm
Machine Size	L 700 x W 503 x H 950 mm
Packing Size	L 690 x W 430 x H 270 mm



S102

Automatic Models



PW-0860A

Options

- 36 straps/min.
- (PW-0860A1, 3/AC1, 3) : PCB control
- Detection for strap not in position
- Detection for no strap
- Stainless steel structure SUS #304
- Single phase (1Ø)



PW-0860AC

PW-0860A/ PW-0860AC Automatic Strapping Machine

A: Machine Frame with Steel Arch

AC: Machine Frame with Aluminum Arch

Power	3Ø, 220/380/415/440V, 50/60Hz
Standard Arch Size	W 850 x H 600 mm (other sizes made on request)
Strap Width	9, 12, 15,19 mm (PET option)
Strapping Tension	0 ~ 70 Kgs
Strapping Speed	2.4 sec./strap (25 strap/min.)
Table Height	810 mm
Machine Size	L 1440 x W 640 x H 1535 mm

Options

- Ball table top
- Detection for strap not in position
- Detection for no strap
- Stainless steel structure SUS #304
- Single phase (1Ø)



PW-0860L



PW-0860CL

PW-0860L/PW-0860CL Automatic Strapping Machine

L: Steel Arch in Low Profile

CL: Aluminum Arch in Low Profile

Power	3Ø, 220/380/415/440V, 50/60Hz
Standard Arch Size	W 850 x H 600 mm (other sizes made on request)
Strap Width	9, 12, 15,19 mm (PET option)
Strapping Tension	0 ~ 70 Kgs
Strapping Speed	2.4 sec./strap (25 strap/min.)
Table Height	450 mm
Machine Size	L 1900 x W 640 x H 1764 mm

Automatic Side Seal Models



PW-0860YS2

Options

- Detection for strap not in position
- Detection for no strap
- Stainless steel structure SUS #304
- Conveyor system (custom made)
- Sensor for 2 straps
- No power roller
- Single phase (1Ø)



PW-0860CYS2

PW-0860YS2 / PW-0860CYS2 Automatic Strapping Machine

Y: Side Seal + 2 Sensors with Steel Arch

CY: Side Seal + 2 Sensors with Aluminum Arch

Power	3Ø, 220/380/415/440V, 50/60Hz
Standard Arch Size	W 600 x H 850 mm (other sizes made on request)
Strap Width	9, 12, 15, 19 mm (PET option)
Strapping Tension	0 ~ 70 Kgs
Strapping Speed	2.4 sec./strap (25 strap/min.)
Sealing point	692 mm from the floor
Machine Size	L 1425 x W 630 x H 1724 mm



PW-0660YTR

Options

- Detection for strap not in position
- Detection for no strap
- Stainless steel structure SUS #304
- Single phase (1Ø)



PW-0660CYTR

PW-0660YTR / PW-0660CYTR Automatic Strapping Machine

YTR: Side Seal Include Free Roller Conveyor with Steel Arch

CYTR: Side Seal Include Free Roller Conveyor with Aluminum Arch

Power	3Ø, 220/380/415/440V, 50/60Hz
Standard Arch Size	W 600 x H 650 mm (other sizes made on request)
Strap Width	9, 12, 15, 19 mm (PET option)
Strapping Tension	0 ~ 70 Kgs
Strapping Speed	2.4 sec./strap (25 strap/min.)
Sealing point	692 mm from the floor
Machine Size	L 1425 x W 631 x H 1727 mm

Fully Automatic Models

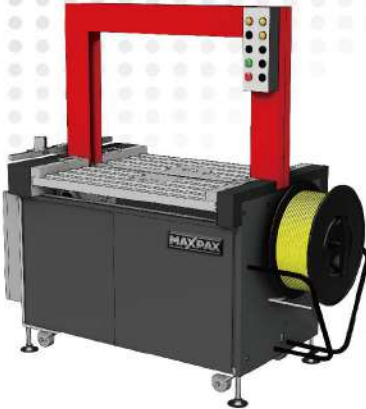

PW-0860AS2R

Options

- Detection for strap not in position
- Detection for no strap
- Stainless steel structure SUS #304
- Single phase (1Ø)



PW-0860CS2R

PW-0860AS2R/ PW-0860CS2R Fully Automatic Strapping Machine

AS2R: Roller Table Drive + 2 Sensors with Steel Arch

CS2R: Roller Table Drive + 2 Sensors with Aluminum Arch

Power	3Ø, 220/380/415/440V, 50/60Hz
Standard Arch Size	W 850 x H 600 mm (other sizes made on request)
Strapping Size (Min.)	L 350 x W 400 x H 30 mm
Strap Width	9, 12, 15,19 mm (PET option)
Strapping Tension	0 ~ 70 Kgs
Strapping Speed	2.4 sec./strap (25 strap/min.)
Max.Loading Weight	100 Kgs
Working Height	810 mm
Machine Size	L 1595 x W 760 x H 1535 mm

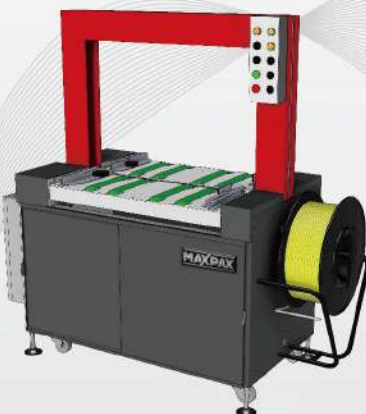

PW-0860AS2B

Options

- Detection for strap not in position
- Detection for no strap
- Stainless steel structure SUS #304
- Single phase (1Ø)



PW-0860CS2B

PW-0860AS2B/ PW-0860CS2B Fully Automatic Strapping Machine

AS2B: Belt Table Drive + 2 Sensors with Steel Arch

CS2B: Belt Table Drive + 2 Sensors with Aluminum Arch

Power	3Ø, 220/380/415/440V, 50/60Hz
Standard Arch Size	W 850 x H 600 mm (other sizes made on request)
Strapping Size (Min.)	L 200 x W 200 x H 30 mm
Strap Width	9, 12, 15,19 mm (PET option)
Strapping Tension	0 ~ 70 Kgs
Strapping Speed	2.4 sec./strap (25 strap/min.)
Max.Loading Weight	20 Kgs
Working Height	810 mm
Machine Size	L 1595 x W 700 x H 1535 mm

Automatic Low Table Models



PW-0860LS2R

Options

- Detection for strap not in position
- Detection for no strap
- Stainless steel structure SUS #304
- Single phase (1Ø)



PW-0860CLS2R

PW-0860LS2R/ PW-0860CLS2R Fully Automatic Strapping Machine

LS2R: Roller Table Drive + 2 Sensors with Steel Arch in Low Profile

CLS2R: Roller Table Drive + 2 Sensors with Aluminium Arch in Low Profile

Power	3Ø, 220/380/415/440V, 50/60Hz
Standard Arch Size	W 850 x H 600 mm (other sizes made on request)
Strap Width	9, 12, 15,19 mm (PET option)
Strapping Tension	0 ~ 70 Kgs
Strapping Speed	2.4 sec./strap (25 strap/min.)
Max.Loading Weight	100 Kgs
Working Height	450 mm
Machine Size	L 2260 x W 760 x H 1774 mm

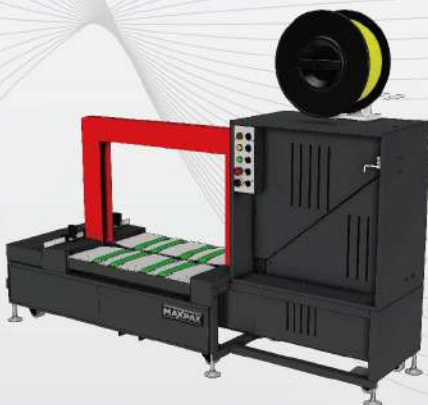

PW-0860LS2B

Options

- Detection for strap not in position
- Detection for no strap
- Stainless steel structure SUS #304
- Single phase (1Ø)

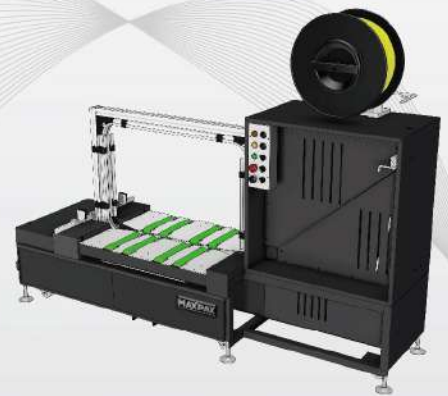

PW-0860CLS2B

PW-0860LS2B/ PW-0860CLS2B Fully Automatic Strapping Machine

LS2B: Belt Table Drive + 2 Sensors with Steel Arch in Low Profile

CLS2B: Belt Table Drive + 2 Sensors with Aluminium Arch in Low Profile

Power	3Ø, 220/380/415/440V, 50/60Hz
Standard Arch Size	W 850 x H 600 mm (other sizes made on request)
Strap Width	9, 12, 15,19 mm (PET option)
Strapping Tension	0 ~ 70 Kgs
Strapping Speed	2.4 sec./strap (25 strap/min.)
Max.Loading Weight	20 Kgs
Working Height	450 mm
Machine Size	L 2260 x W 760 x H 1774 mm

Fully Automatic Models

PW-0860AS2BS Fully Automatic Strapping Machine

AS2BS: Belt Table Drive + 2 Sensors with Steel Arch

Power	3Ø, 220/380/415/440V, 50/60Hz
Standard Arch Size	W 850 x H 600 mm (other sizes made on request)
Strapping Size (Min.)	W 350 x W 110 x H 30 mm
Strap Width	9, 12, 15, 19 mm (PET option)
Strapping Tension	0 ~ 70 Kgs
Strapping Speed	2.4 sec./strap (25 strap/min.)
Max. Loading Weight	20 Kgs
Working Height	810 mm
Machine Size	L 1094 x W 640 x H 1517 mm

Features

- Belt table drive (Fully covered)
- Automatic sensor strapping
- Special table design, for most of packing sizes

Options

- Conveyor system
- PLC controller
- Aluminum arch



PW-0860AS2BS

Advanced Fully Automatic Models

PW-0860CAT Automatic Strapping Machine

CAT: Auto Strap Loading with Aluminum Arch

Power	3Ø, 220/380/415/440V, 50/60Hz
Standard Arch Size	W 850 x H 600 mm (other sizes made on request)
Strap Width	9, 12, 15, 19 mm
Strapping Tension	0 ~ 70 Kgs
Strapping Speed	30 straps/min.
Working Height	810 mm
Machine Size	L 1094 x W 640 x H 1517 mm

Features

- Automatic strap loading
- Mechanical tension adjustment
- Automatic strap re-feed system
- Strap ejector device
- Strap tension of up to 70 Kgs
- Accurate Strapping Position
- Electromagnetic Dispenser Brake
- Detection for no strap (for online system)

Options

- Stainless steel structure SUS #304
- Single phase (1Ø)
- Steel Arch



PW-0860CAT

PW-0860CATS2R Fully Automatic Strapping Machine

CATS2R: Auto Strap Loading + Roller Table Driven+ 2 sensors in Aluminum Arch

Power	3Ø, 220/380/415/440V, 50/60Hz
Standard Arch Size	W 850 x H 600 mm (other sizes made on request)
Strap Width	9, 12, 15,19 mm
Strapping Tension	0 ~ 70 Kgs
Strapping Speed	30 straps/min.
Conveyor Speed	20 M/min.
Working Height	810 mm
Machine Size	L 1605 x W 760 x H 1517 mm

Features

- Automatic strap loading
- Mechanical tension adjustment
- Automatic strap re-feed system
- Strap ejector device
- Strap tension of up to 70 Kgs
- Accurate Strapping Position
- Embossed Roller
- Electromagnetic Dispenser Brake

Options

- Detection for no strap (for online system)
- Stainless steel structure SUS #304
- Steel Arch



PW-0860CATS2R

High Speed Automatic Models

PW-0540DUAT Automatic Strapping Machine

DUAT: High Speed strapping with UPE Arch and Auto Strap Loading

Power	1Ø, 110/220/240V, 50/60Hz
Standard Arch Size	W 550 x H 400 mm (other sizes made on request)
Strap Width	5,6,9 mm
Strapping Tension	1 ~ 30 Kgs
Strapping Speed	55 straps/min.
Working Height	870 ~ 950 mm
Machine Size	L 1037 x W 570 x H 1397 mm

Options

- Detection for no strap (for online system)
- Stainless steel structure SUS #304
- Three phase (3Ø)

Features

- Strapping speed of up to 1.05 sec./strap
- New strapping head with servo motors for maximum speed performance
- Auto loop ejector
- UPE Arch
- Built-in strap dispenser
- Strap-end remover with open arch function
- Strap tension from 1 to 30 kgs
- Fast remove strapping head and front plate without any tools for maintenance and time savings



PW-0540DUAT

High Speed Automatic Model with Top Press

PW-2850DUATS3R+P Automatic Strapping Machine

DUATS3R+P: High Speed Strapping with UPE Arch, Auto Strap Loading and Roller Driven with 3 Sensors + Top Press Device

Power	3Ø, 220/380/415/440V, 50/60Hz
Standard Arch Size	W 1250 x H 500 mm (other sizes made on request)
Strap Width	5,6,9 mm
Strapping Tension	1 ~ 30 Kgs
Strapping Speed	42 straps/min.
Conveyor Speed	30 M/min.
Air	6kgf/cm ²
Working Height	790~890 mm
Machine Size	L 2140 x W 720 x H 1530 mm

Features

- Strapping speed of up to 1.05 sec./strap
- New strapping head with servo motors for maximum speed performance
- Auto loop ejector
- UPE Arch
- Strap-end remover with open arch function
- Strap tension from 1 to 30 kgs
- With top press device

Options

- Detection for no strap (for online system)
- Stainless steel structure SUS #304

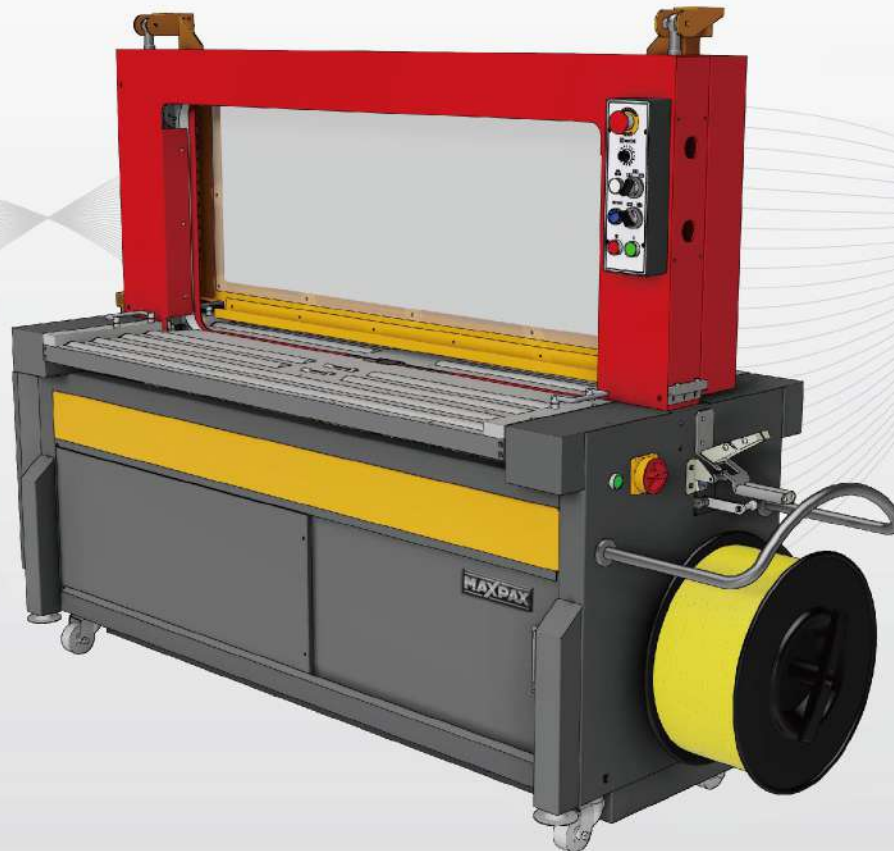

PW-2850DUATS3R+P

U-Series Pallet Strapping Models

PW-2862UYA0V Vertical Palletizing Strapping Machine

UYA0V: High Speed Strapping Head for Top Sealing

Power	3Ø, 220/380/415/440V, 50/60Hz
Arch Size	W 1250 x H 1000 mm (other sizes made on request)
PET Strap Width	9, 12, 15, 19 mm x 406 (ID)
Strapping Tension	40 ~ 400 Kgs (according to PET width)
Strapping Speed	10 sec./strap. (Exclude Convey Time)
Sealing Method	Electric Heat Seal
Air	6 KGf/CM ²
Min. Strapping Height	370 mm (with pallet)
Detection	Detection for strap not in position Detection for no strap Detection for strap failure
Min. Conveyor Height	500 mm
Machine Size	L3236xW1000xH2571 mm

Features

- Pneumatic driven lance
- Height memory function
- Tension pool with no strap detection
- Strap Feed & Reverse : Servo motor controlled
- U Series strapping tension force up to 400 kgs (base on 19mm PET)

Options

- Conveyor system
- Custom Made
- Fixed Arch

PP strap adustable tension

- 40~130 Kgs (9mm)
- 40~180 Kgs (12mm)
- 40~240 Kgs (15mm)
- 40~260 Kgs (19mm)

PET strap adustable tension

- 40~200 Kgs (9mm)
- 40~250 Kgs (12mm)
- 40~350 Kgs (15mm)
- 40~400 Kgs (19mm)

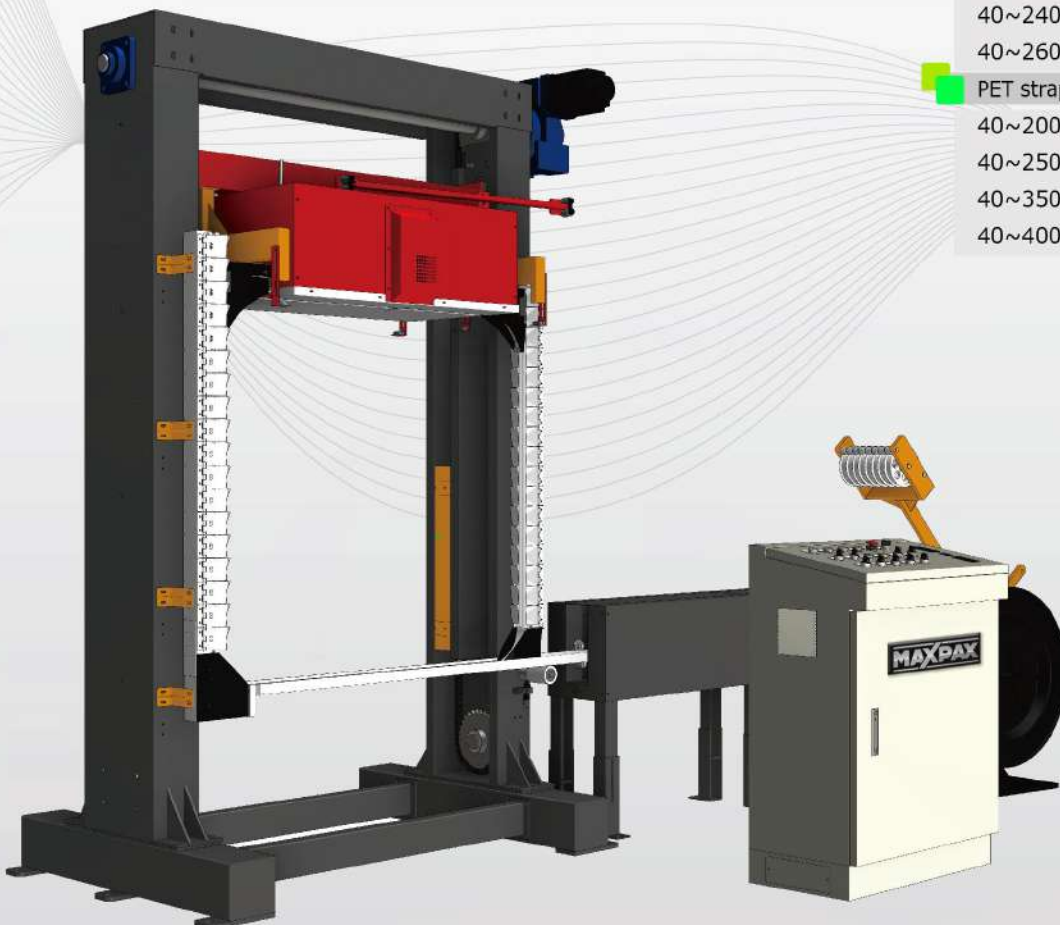

PW-2862UYA0V

PW-2862UYAOP Vertical Palletizing Strapping Machine

UYAOP: High Speed Strapping Head for Top Sealing with Press

Power	3Ø, 220/380/415/440V, 50/60Hz
Arch Size	W 1250 x H 1000 mm (other sizes made on request)
PET Strap Width	9, 12, 15, 19 mm x 406 (ID)
Strapping Tension	40 ~ 400 Kgs (according to PET width)
Strapping Speed	30 sec./strap. (Exclude Convey Time)
Sealing Method	Electric Heat Seal
Air	6 KGf/CM ²
Top Press Power	1000 Kgs
Detection	Detection for strap not in position Detection for no strap Detection for strap failure
Min. Conveyor Height	400 mm
Machine Size	L3154xW1000xH2194 mm

Features

- Pneumatic driven lance
- Height memory function
- Tension pool with no strap detection
- Strap Feed & Reverse : Servo motor controlled
- U Series strapping tension force up to 400 kgs (base on 19mm PET)

Options

- Conveyor system
- Custom Made
- Fixed Arch

PP strap adustable tension

- 40~130 Kgs (9mm)
- 40~180 Kgs (12mm)
- 40~240 Kgs (15mm)
- 40~260 Kgs (19mm)

PET strap adustable tension

- 40~200 Kgs (9mm)
- 40~250 Kgs (12mm)
- 40~350 Kgs (15mm)
- 40~400 Kgs (19mm)

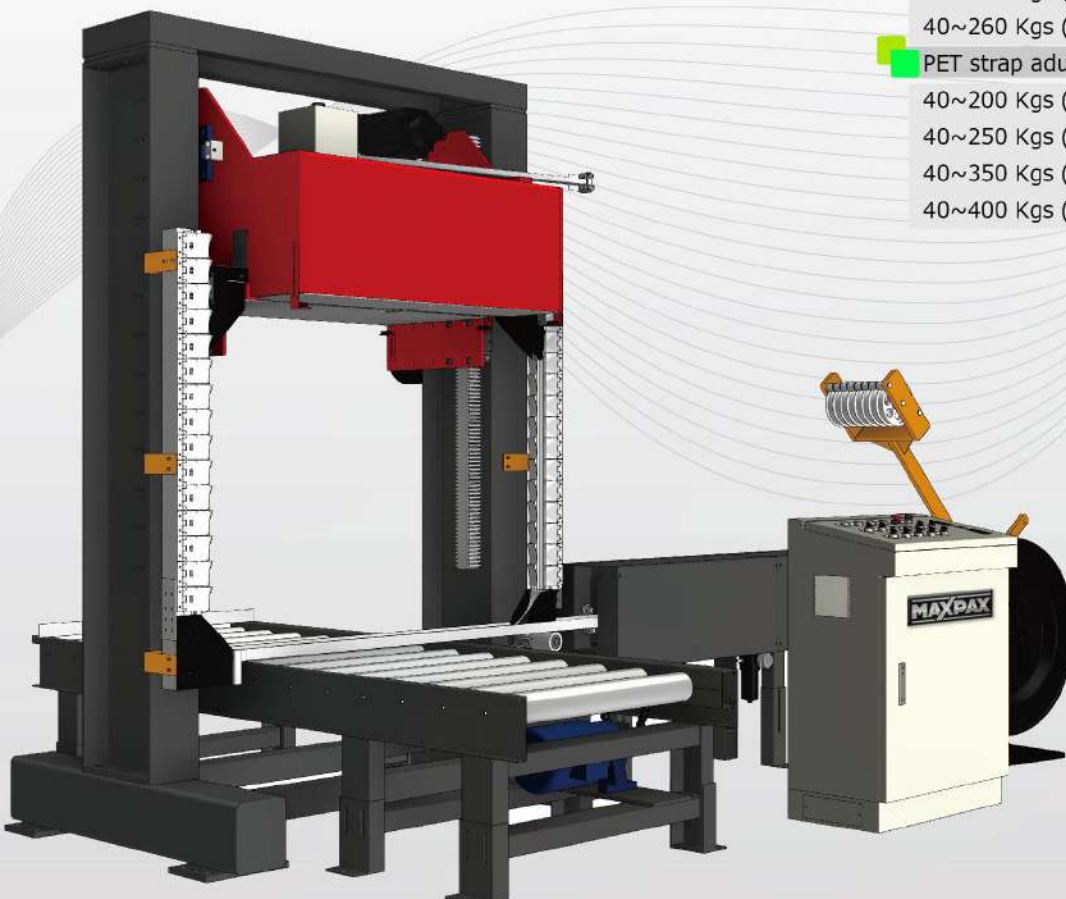

PW-2862UYAOP

PW-2862UYAO Vertical Palletizing Strapping Machine

UYAO: High Speed Strapping Head for Side Sealing

Power	3Ø, 220/380/415/440V, 50/60Hz
Arch Size	W 1000x H 1250 mm (other sizes made on request)
PET Strap Width	9, 12, 15, 19 mm x 406 (ID)
Strapping Tension	40 ~ 400 Kgs (according to PET width)
Strapping Speed	15 sec./strap. (Exclude Convey Time)
Sealing Method	Electric Heat Seal
Air	6 KGf/CM ²
Head Moving Interval	250mm (other sizes made on request)
Detection	Detection for strap not in position Detection for no strap Detection for strap failure
Min. Conveyor Height	250 mm
Machine Size	L3079xW781xH1971 mm

Features

- Pneumatic driven lance
- Tension pool with no strap detection
- Strap Feed & Reverse : Servo motor controlled
- U Series strapping tension force up to 400 kgs (base on 19mm PET)

Options

- Conveyor system
- Custom Made
- Fixed Arch

PP strap adustable tension

- 40~130 Kgs (9mm)
- 40~180 Kgs (12mm)
- 40~240 Kgs (15mm)
- 40~260 Kgs (15mm)

PP strap adustable tension

- 40~200 Kgs (9mm)
- 40~250 Kgs (12mm)
- 40~350 Kgs (15mm)
- 40~400 Kgs (19mm)



PW-2862UYAO

PW-2862UHE Horizontal Palletizing Strapping Machine

UHE: High Speed Strapping Head in Horizontal Movement

Power	3Ø, 220/380/415/440V, 50/60Hz
Arch Size	W 1250 x H 1000 mm (other sizes made on request)
PET Strap Width	9, 12, 15, 19 mm x 406 (ID)
Strapping Tension	40 ~ 400 Kgs (according to PET width)
Strapping Speed	12 sec./strap. (Exclude Convey Time)
Sealing Method	Electric Heat Seal
Air	6 KGf/CM ²
Head Moving Interval	250mm (other sizes made on request)
Detection	Detection for strap not in position
	Detection for no strap
	Detection for strap failure
Min. Conveyor Height	500 mm
Machine Size	L2087xW1651xH2130 mm

Features

- Height memory function
- Tension pool with no strap detection
- Strap Feed & Reverse : Servo motor controlled
- U Series strapping tension force up to 400 kgs (base on 19mm PET)

Options

- Conveyor system
- Custom Made

PP strap adustable tension

- 40~130 Kgs (9mm)
- 40~180 Kgs (12mm)
- 40~240 Kgs (15mm)
- 40~260 Kgs (19mm)

PET strap adustable tension

- 40~200 Kgs (9mm)
- 40~250 Kgs (12mm)
- 40~350 Kgs (15mm)
- 40~400 Kgs (19mm)



PW-2862UHE

U-Series Pallet Strapping Models - Fixed Arch

PW-4874UYAV Vertical Palletizing Strapping Machine

UYAV: High Speed Strapping Head for Top Sealing

Power	3Ø, 220/380/415/440V, 50/60Hz
Standard Arch Size	W 1650 x H 1500 mm (other sizes made on request)
PET Strap Width	9, 12, 15, 19 mm x 406 (ID)
Strapping Tension	40 ~ 400 Kgs (according to PET width)
Strapping Speed	10 sec./strap. (Exclude Convey Time)
Sealing Method	Electric Heat Seal
Detection	Detection for strap not in position Detection for no strap Detection for strapping failure
Min. Conveyor Height	500 mm
Machine Size	L 3100 x W 1770 x H 2912 mm

Features

- Height memory function
- Tension pool with no strap detection
- Strap feed & reverse:
Servo motor controlled
- U Series strapping tension force up to 400 kgs (base on 19mm PET)

Options

- Conveyor system
- Custom Made

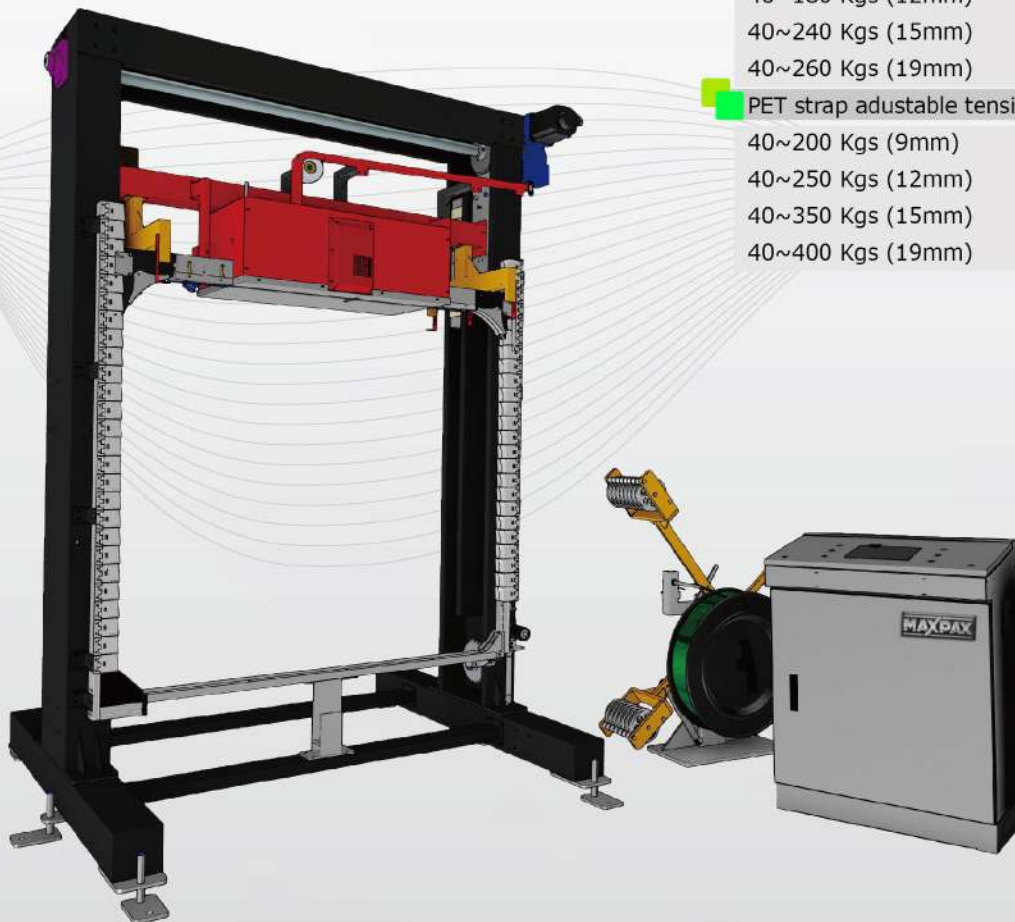

PP strap adjustable tension

- 40~130 Kgs (9mm)
- 40~180 Kgs (12mm)
- 40~240 Kgs (15mm)
- 40~260 Kgs (19mm)

PET strap adjustable tension

- 40~200 Kgs (9mm)
- 40~250 Kgs (12mm)
- 40~350 Kgs (15mm)
- 40~400 Kgs (19mm)

PW-4874UYAV

PW-4865UYA Vertical Palletizing Strapping Machine

UYA:High Speed Strapping Head for Side Sealing

Power	3Ø, 220/380/415/440V, 50/60Hz
Standard Arch Size	W 1650 x H 1600 mm (other sizes made on request)
PET Strap Width	9, 12, 15, 19 mm x 406 (ID)
Strapping Tension	40 ~ 400 Kgs (according to PET width)
Strapping Speed	15 sec./strap. (Exclude Convey Time)
Sealing Method	Electric Heat Seal
Air	6 Kgf/cm ²
Head Moving Interval	250 mm (other sizes made on request)
Detection	Detection for strap not in position Detection for no strap Detection for strapping failure
Min. Conveyor Height	250 mm
Machine Size	L 4150 x W 728 x H 2060 mm

Features

- Strapping head move:Pneumatic driven
- Tension pool with no strap detection
- Strap feed & reverse:
Servo motor controlled
- U Series strapping tension force up to 400 kgs (base on 19mm PET)

Options

- Conveyor system
- Custom Made

PP strap adustable tension

- 40~130 Kgs (9mm)
- 40~180 Kgs (12mm)
- 40~240 Kgs (15mm)
- 40~260 Kgs (19mm)

PET strap adustable tension

- 40~200 Kgs (9mm)
- 40~250 Kgs (12mm)
- 40~350 Kgs (15mm)
- 40~400 Kgs (19mm)



PW-4865UYA

U-Series Pallet Strapping Models - Low Profile Fixed Arch

PW-4863UYAOL Vertical Palletizing Strapping Machine-Low Profile

UYAOL:High Speed Strapping Head for Side Sealing

Power	3Ø, 220/380/415/440V, 50/60Hz
Arch	W 1650 x H 1200 mm (other sizes made on request)
PET Strap Width	9, 12, 15, 19 mm x 406 (ID)
Strapping Tension	40 ~ 400 Kgs (according to PET width)
Strapping Speed	16 sec./strap. (Exclude Convey Time)
Sealing Method	Electric Heat Seal
Head Moving Interval	250mm (other sizes made on request)
Detection	Detection for strap not in position Detection for no strap Detection for straping failure
Min. Conveyor Height	150 mm
Machine Size	L 3510 x W 830 x H 2010 mm

Features

- Strapping head move:Motor driven
- Lance Move:Motor driven
- Tension pool with no strap detection
- Strap feed & reverse:
Servo motor controlled
- U Series strapping tension force up to 400 kgs (base on 19mm PET)

Options

- Conveyor system
- Custom made

PP strap adustable tension

- 40~130 Kgs (9mm)
- 40~180 Kgs (12mm)
- 40~240 Kgs (15mm)
- 40~260 Kgs (19mm)

PET strap adustable tension

- 40~200 Kgs (9mm)
- 40~250 Kgs (12mm)
- 40~350 Kgs (15mm)
- 40~400 Kgs (19mm)



PW-4863UYAOL

Standard Pallet Strapping Models

PW-5765YAOV Vertical Palletizing Strapping Machine

YAOV: Strapping Head Moves Vertically

Power	3Ø, 220/380/415/440V, 50/60Hz
Arch Size	W 1750 x H 1600 mm (other sizes made on request)
PP Strap Width	12, 15, 19 mm
PET Strap Width	9, 12, 15, 19 mm x 406(ID)
Strapping Tension	0 ~ 70 Kgs
Strapping Speed	20 sec./strap. (Exclude Convey Time)
Sealing Method	Electric Heat Seal
Air	6 Kgf/cm ² (lance with electronic driven)
Detection	Detection for strap not in position
	Detection for no strap
	Detection for straping failure
Min. Conveyor Height	300 mm
Machine Size	L 4150 x W 970 x H 2538 mm

Features

- Lance move : Electric
- Automatic strapping, cutting and welding

Options

- Strapping tension of 100 Kgs
- Conveyor system
- Custom Made
- Fixed Arch



PW-5765YAOV

PW-3864YAO Vertical Palletizing Strapping Machine

YAO: Strapping Head for Side Sealing

Power	3Ø, 220/380/415/440V, 50/60Hz
Arch Size	W 1400 x H 1450 mm (other sizes made on request)
PP Strap Width	12, 15, 19 mm
PET Strap Width	9, 12, 15, 19 mm x 406(ID)
Strapping Tension	0 ~ 70 Kgs
Strapping Speed	25 sec./strap. (Exclude Convey Time)
Sealing Method	Electric Heat Seal
Air	6 Kgf/cm ² (lance with electronic driven)
Head Moving Interval	250mm (other sizes made on request)
Detection	Detection for strap not in position Detection for no strap Detection for strap failure
Min. Conveyor Height	300 mm
Machine Size	L 4308 x W 1650 x H 2967 mm

Features

- Lance move : Electric
- Strapping head move : Electric
- Automatic strapping, cutting and welding

Options

- Top press mechanism (PW-3864YAOP)
- Strapping tension of 100 Kgs
- Conveyor system
- Custom Made
- Fixed Arch

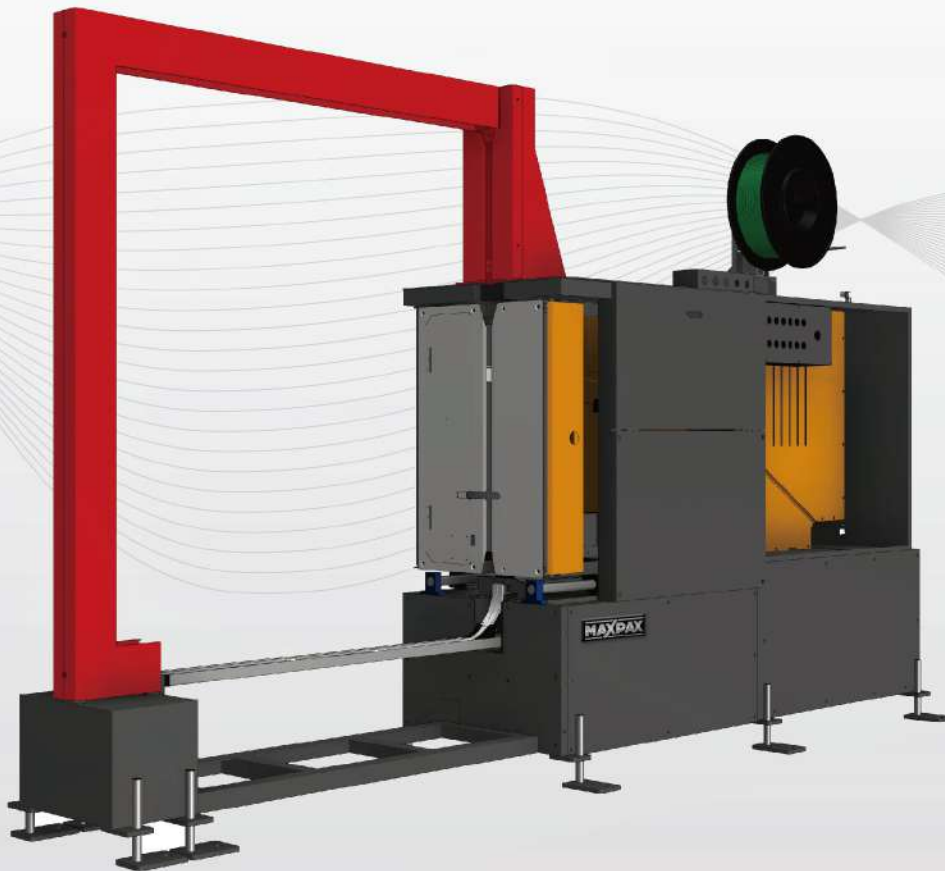

PW-3864YAO

Combination Machines

PW-553SB + PW-0860CAT Carton Sealing Machine + Auto Strapping Machine

PW-553SB : Side Driven with Extended Belt

Power	"3Ø, 220/380/415/440V, 50/60Hz1Ø, 110/220V, 50/60Hz"
OPP Tape	2" or 3"
Sealing Range	L300~700 x W120~500 x H110~500 mm (2"),(3" W+25 mm)
Capacity	8 Carton / Min. for box length 300 mm (Belt Speed 20M/min)
Machine Size	L1648xW970xH1761 mm

PW-0860CAT : Auto Strap Loading with Aluminum Arch

Ref Page11



PW-553SB + PW-0860CAT



PW-555AB + PW-0860CATS2R

PW-555AB + PW-0860CATS2R Fully Auto Sealing Machine + Roller Driven Fully Auto Strapping Machine

PW-555AB : Auto Side Driven with Extended Belt Random

Power	3Ø, 220/380/415/440V, 50/60Hz, 1Ø, 110/220V, 50/60Hz
OPP Tape	2" or 3"
Sealing Range	L300~∞ x W120~500 x H150~500 mm (2") ,(3" W+25 mm)
Capacity	8 Carton / Min. for box length 300 mm (Belt Speed 20M/min)
Machine Size	L1650 x W 930 x H1576 mm

PW-0860CATS2R : Auto strap Loading with Roller Table Driven in Aluminum Arch

Ref Page13

PACKAGING SYSTEMS

copy right ©

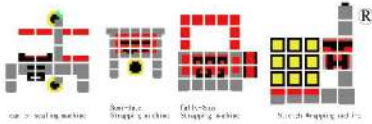

We pack your way

(H) - (I) are for PP and PET straps with adjustable tension
For PET Straps:
40Kgs-400Kgs(19mm)
40Kgs-350Kgs(15mm)
40Kgs-250Kgs(12mm)
40Kgs-200Kgs(9mm)
☆ Patent under application.

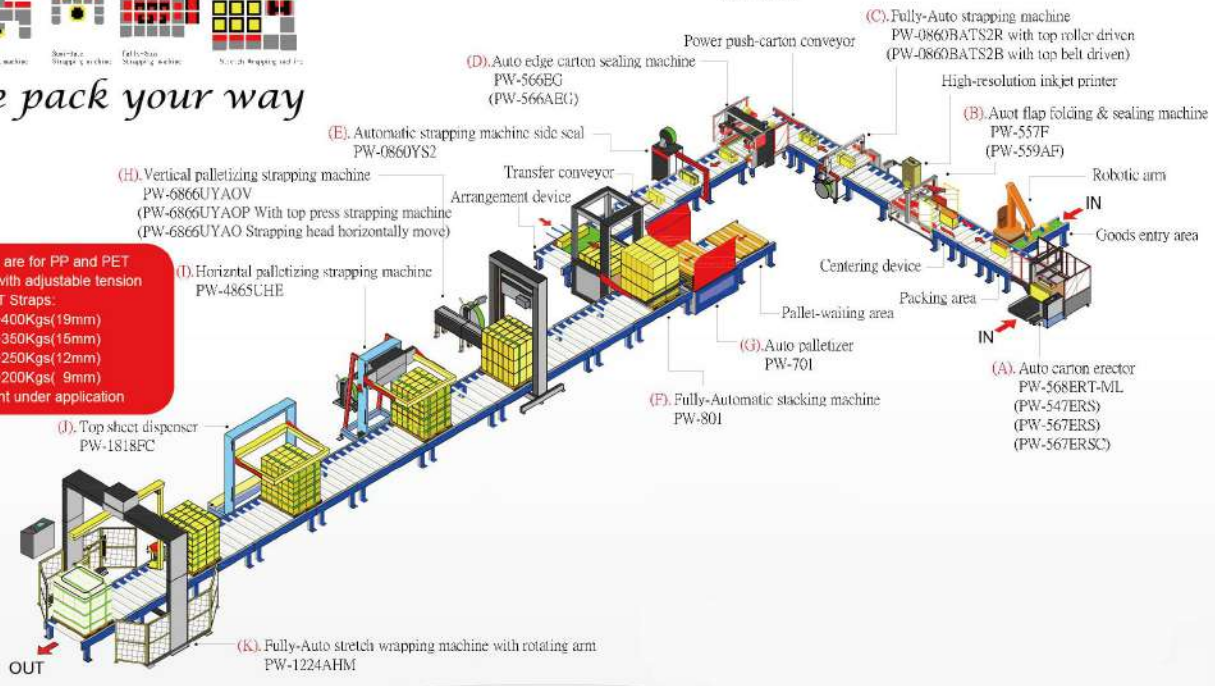

PW-0860BAT+PW-557FB+PW-53+PW-568ERT



PW-4865CLP+S6



Flexible Pick & Place with Sealing System



PW-553S+PW-0840AS2+PW-801



JAKARTA

Jalan Gunung Sahari XI No. 76A

021 623 20 700

jakarta@wiratech.co.id

SURABAYA

Jalan Bubutan 79

031 545 88 53

surabaya@wiratech.co.id

WIRATECH.CO.ID