



 **WIRATECH**

CATALOGUE



WIRATECH.CO.ID

DAFTAR ISI



SEALER		ICE MACHINE	
HAND SEALER	1	DISPLAY COOLER	29
FOOT SEALER	2	ICE CREAM MACHINE	30
CONTINUOUS SEALER	3	ICE CUBE MAKER	31
GAS CONTINUOUS SEALER	4	JUICE DISPENSER	32
HEAVY DUTY CONTINUOUS SEALER	5	ICE CRUSHER	32
CUP SEALER	6	MEAT MACHINE	
VACUUM MACHINE		MEATBALL MAKER	33
HOUSEHOLD VACUUM SEALER	7	MEAT MIXER	34
SINGLE CHAMBER VACUUM MACHINE	8	BOWL CUTTER	34
DOUBLE CHAMBER VACUUM MACHINE	9	MEAT SLICER	35
GAS SUCTION VACUUM MACHINE	9	BONE SAW	35
MAXPAX VACUUM SEALER	10	MEAT GRINDER	36
PACKING MACHINE		SAUSAGE MAKER	36
CARTON SEALER	11	BAKERY MACHINE	
STRAPING MACHINE	12	HOUSEHOLD MIXER	37
SHRINK MACHINE	13	PLANETARY MIXER	38
SHRINK HOOD MACHINE	14	SPIRAL MIXER	38
SEAL CUTTING MACHINE	15	HORIZONTAL MIXER	39
SLEEVE SEAL CUTTING MACHINE	16	BREAD SLICER	39
CODING MACHINE	17	GAS DECK OVEN	40
INDUCTION SEALER	18	ELECTRIC PROOFER	40
PISTON FILLING	19	HORECA EQUIPMENT	
CREAM FILLING	20	FOOD DEHYDRATOR	42
CUP FILLING	20	DISPLAY WARMER	42
FILLING WEIGHING MACHINE	21	DEEP FRYER	43
VERTICAL FILLING MACHINE	22	GAS GRIDDLE	44
HORIZONTAL WRAPPER	23	RICE STEAMER	44
PALLET WRAPPER	24	POP CORN MACHINE	45
SKIN MACHINE	25	CANDY FLOSS MACHINE	45
BLISTER MACHINE	25	BLENDER	45
CAPPING MACHINE	26		
LABELING MACHINE	26		
FOLDING MACHINE	26		
PLASTIC PACKAGING	27		

WIRAPRO

HAND PALLET		47
HAND STACKER		48



WIRAPAX

HAND SEALER

FS SERIES

Hand Sealer tersedia dengan 2 pilihan material (Besi atau Alumunium) dan juga 2 pilihan lebar seal (5 atau 10 mm).

Mudah digunakan untuk menyegel berbagai macam plastik contoh seperti plastik PP dan PE.

MORE INFO



Kelebihan :



Travo Besar



Safety Fuse

MODEL	IMPULSE POWER (W)	SEALING LENGTH (mm)	SEALING WIDTH (mm)	MAX SEAL THICKNESS (mm)	HEAT TIME (S)	MACHINE SIZE PACKING SIZE (cm)	NET/GROSS WEIGHT (Kg)
FS-200	260	200	2	0.2	0.2 - 1.3	33×8×14 34×10×18	2.1 kg / 3 kg
FS-300	430	300	3	0.3	0.2 - 1.3	43×9×16 46×11×33	4 kg / 5 kg
FS-400	600	400	3	0.3	0.2 - 1.3	55×9×17 58×10×19	4 kg / 5 kg
FS-205	360	200	5	0.2	0.2 - 1.3	33×8×14 34×10×18	2.1 kg / 3 kg
FS-305	600	300	5	0.3	0.2 - 1.3	43×9×16 46×11×33	4 kg / 5 kg
FS-405	700	400	5	0.3	0.2 - 1.3	55×9×17 58×10×19	4 kg / 5 kg

FS-H SERIES

Hand Sealer berukuran panjang 60 cm sampai dengan 100 cm. Bodi mesin terbuat dari alumunium sehingga ringan dan mudah dibawa-bawa

Cocok untuk merekatkan plastik yang berukuran besar berjenis PP dan PE.

MORE INFO



Kelebihan :



Timer



Material Kokoh

MODEL	IMPULSE POWER (W)	SEALING LENGTH (mm)	SEALING WIDTH (mm)	MAX SEAL THICKNESS (mm)	HEAT TIME (S)	MACHINE SIZE PACKING SIZE (cm)	NET / GROSS WEIGHT
FS-600H	780	600	3	2.8	0.2 - 3	80×11×23 87×15×29	5.5 kg / 6.5 kg
FS-800H	1050	800	3	2.8	0.2 - 3	100×11×23 108×15×29	6 kg / 7 kg
FS-1000H	1350	1000	3	2.8	0.2 - 3	120×11×23 128×15×29	6.5 kg / 7.5 kg

FOOT SEALER

PFS- SERIES

Kelebihan :



Timer

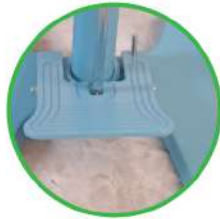

Pijakan Kaki



Foot Sealer dioperasikan dengan menggunakan pijakan kaki. Tersedia 2 pilihan ukuran lebar seal (5 & 10 mm).

Bisa di gunakan untuk segala jenis plastik kemasan makanan dan lainnya.

MORE INFO



MODEL	IMPULSE POWER (W)	SEALING LENGTH (mm)	SEALING WIDTH (mm)	HEAT TIME (S)	MACHINE SIZE PACKING SIZE (cm)	NET / GROSS WEIGHT
PFS 350	1200	350	5 / 10	0 - 2.5	45×54×88 80×56×27	19 kg / 21 kg
PFS 450	1250	450	5 / 10	0 - 2.5	55×54×88 80×56×27	21 kg / 23 kg
PFS 650	1500	650	5 / 10	0 - 2.5	70×57×88 80×56×27	24 kg / 26 kg
PFS 800	1800	800	5 / 10	0 - 2.5	85×57×88 94×56×27	25 kg / 28 kg

Kelebihan :



Digital Timer

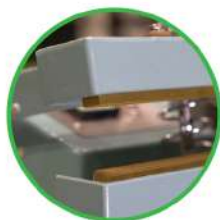

Pemanas Kuningan



PFS-DD memiliki sistem pemanasan Direct Heating dengan menggunakan elemen pemanas dua sisi atas & bawah yang anti lengket.

Cocok untuk jenis kemasan Metalized dan Aluminium Foil.

MORE INFO



MODEL	VOLTAGE (V/Hz)	POWER (W)	SEALING LENGTH (mm)	SEALING WIDTH (mm)	MACHINE SIZE PACKING SIZE (cm)	NET / GROSS WEIGHT
PFS 300DD	AC 220/50	200×2	300	14	35×49×88 80×55×25	16 kg / 18 kg
PFS 400DD	AC 220/50	200×2	400	14	45×49×88 80×55×25	17 kg / 19 kg

CONTINUOUS SEALER

FRB-888 SERIES

- FRB-888 memiliki bodi Painted Steel
- Continuous Sealer memiliki kelebihan bisa menyegel produk secara terus menerus dengan bantuan ban berjalan (conveyor).

MORE DETAIL



FRB-888i



FRB-888ii

MODEL	TOTAL POWER (W)	SEALING WIDTH (mm)	DISTANCE FROM THE SEALING CENTER OF THE CONVEYING TABLE (mm)	CONVEYOR SIZE (mm)	MACHINE SIZE PACKING SIZE (cm)	NET /GROSS WEIGHT
FRB 888i	680	10	10 - 40	844×153	84×38×32 89×43×37	21 kg / 25 kg
FRB 888ii	680	10	150 - 270	844×153	84×38×55 89×43×37	28 kg / 32 kg

FRB-770 SERIES

Kelebihan :

- FRB-770 memiliki bodi Stainless Steel tahan karat.
- Continuous Sealer tipe ini memiliki 3 varian, Horizontal (i) & Horizontal dengan kaki (iii) cocok untuk produk padat. Sedangkan jenis Vertikal (ii) cocok untuk produk cairan.



Motor Besar



Gear Besi



Safety Switch

MORE DETAIL



FRB-770i



FRB-770ii



FRB-770iii

MODEL	TOTAL POWER (W)	SEALING WIDTH (mm)	DISTANCE FROM THE SEALING CENTER OF THE CONVEYING TABLE (mm)	CONVEYOR SIZE (mm)	MACHINE SIZE PACKING SIZE (cm)	NET /GROSS WEIGHT
FRB 770i	650	10	10 - 40	840×153	84×38×32 89×43×37	21 kg / 25 kg
FRB 770ii	650	10	150 - 270	840×153	84×38×55 89×43×37	25 kg / 29 kg
FRB 770iii	650	10	10 - 40	840×153	84×55×80 89×43×37	30 kg / 33 kg

GAS CONTINUOUS SEALER

SF-150G

- SF-150G adalah jenis continuous sealer yang di lengkapi dengan blower untuk memompakan udara kedalam kantong sebelum disegel agar produk di dalamnya tidak pecah/rusak.
- Cocok untuk jenis produk kerupuk, keripik buah, roti, dll.



CONTROLLER



BIG BLOWER



BLOWING RESULT



MORE DETAIL



MODEL	POWER (W)	SEALING WIDTH (mm)	SEALING SPEED (m/min)	TEMPERATURE RANGE (°C)	PRINTING TYPE
SF-150G	700	12	0-12	0 - 300	Embossing
	SEALING FILM THICKNESS (mm)	CONVEYOR LOADING (KG)	MACHINE SIZE PACKING SIZE	NET WEIGHT / GROSS WEIGHT	
	0.02-0.08	≤ 3	94×65×90 cm 102×56×99 cm	39 kg 57 kg	

FRM-980 SERIES

- FRMC-980iii (Menyedot Udara)
- FRMQ-980iii (Meniup Udara)
- FRMQ-980iiiN (Meniup Nitrogen)

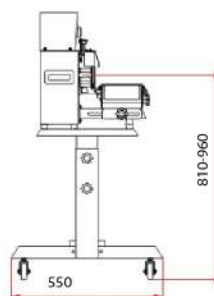
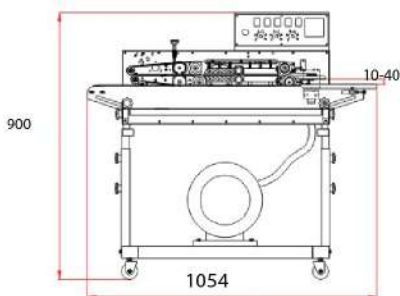

MORE DETAIL



MODEL	POWER (W)	SEALING WIDTH (mm)	DISTANCE FROM THE SEALING CENTER OF THE CONVEYING TABLE (mm)	CONVEYOR SIZE (mm)	MACHINE SIZE PACKING SIZE (cm)	NET / GROSS WEIGHT (Kg)
FRMQ 980III	900	10	10 - 40	930×153	105×56×90 117×58×99	56 kg / 76 kg
FRMC 980III	900	10	10 - 40	930×153	105×56×90 117×58×99	56 kg / 76 kg

HEAVYDUTY CONTINUOUS SEALER

FRM SERIES



FRM-1120LD / FRM-1370LD



FRM-1370AL/M



FRM-1370AL/L

MORE DETAIL



MODEL	FRM-1120LD	FRM-1370LD	FRM-1370AL/M	FR-1370AL/L
TOTAL POWER (W)	1450 watt	1450 watt	1950 watt	1950 watt
SEALING WIDTH (mm)	10 mm	10 mm	10 mm	10 mm
PRINTING TYPE	Solid Ink Coding	Solid Ink Coding	Solid Ink Coding	-
BODY MATERIAL	Stainless Steel	Stainless Steel	Stainless Steel	Painted
DISTANCE SEALING BAR TO CONVEYOR TABLE	100-700 mm	100-700 mm	330-530 mm	300-900 mm
CONVEYOR TABLE SIZE	1400×250 mm	1600×250 mm	1900×300 mm	2400×350 mm
CONVEYOR LOADING	≤ 15 kg	≤ 15 kg	≤ 30 kg	≤ 60 kg
MACHINE SIZE PACKING SIZE	143×68×148 cm 155×70×172 cm	145×68×148 cm 178×70×188 cm	214×55×110 cm 234×67×124 cm	256×72×167 cm 276×93×191 cm
NET WEIGHT GROSS WEIGHT	136 kg 230 kg	150 kg 245 kg	216 kg 266 kg	260 kg 352 kg

CUP SEALER

ET SERIES



ET-D1



ET-A9



ET-H3

MORE DETAIL



MODEL	TYPE	COUNTER	TOTAL POWER (w)	WEIGHT (kg)	CAPACITY (cup /hour)	SIZE (mm)
ET-D1	Manual	Yes/No	300	11.7	300-500	290×280×510
ET-A9	Semi Auto	No	340	15	300-500	282×340×540
ET-H3	Automatic	Yes	360	17	300-500	250×375×565

VACUUM SEALER



HOUSEHOLD



DZ-280X



DZ-290A



DZ-300N

MODEL	SEALING POWER (W)	SEALING LENGTH (mm)	SEALING WIDTH (mm)	MACHINE SIZE PACKING SIZE (cm)	NET / GROSS WEIGHT (kg)
DZ-300N	60	300	2.5	37.5 × 88 × 64	0.71 / 1
DZ-280X	150	280	2.5	35 × 14 × 7 39 × 11 × 18	1.5 / 2
DZ-290A	220	290	2.5	39 × 14 × 7 43 × 12 × 20	2.5 / 3

VACUUM SEALER

TABLE TOP



Latest Technology Vacuum Pump



Removable Heater



HVC-260T

- Mesin Vacuum berfungsi untuk menyedot udara didalam kantong dan kemasan sekaligus menyegel produk.
- Membuat produk yang dikemas tahan lama.

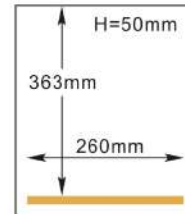

SINGLE CHAMBER

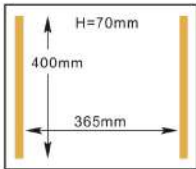

DZ-400/2E

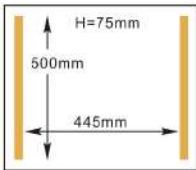

DZ-500/2E



DZ-400/2E DZ-500/2E



DZ-800/2L DZ-1100/2L

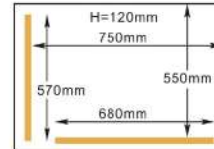

DZ-800/2L

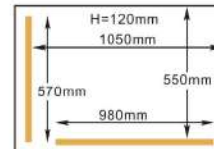

DZ-1100/2L



MODEL	HVC-260T	DZ-400/2E	DZ-500/2E	DZ-800/2L	DZ-1100/2L
MOTOR POWER (W)	370	900	900	1800	1800
SEALING POWER (W)	150	500	600	1000	1500
NO. OF SEAL BAR FOR EACH CHAMBER	1	2	2	2	2
SEALING LENGTH (mm)	260	400×10	500×10	570	570
SEALING WIDTH (mm)	10	10	10	680	980
ULTIMATE VACUUM PRESSURE (KPa)	1.0	1.0	1.0	1.0	1.0
VACUUM PUMP RATE (m ³ /h)	8	20	20	20×2	20×2
MATERIAL OF VACUUM CHAMBER	Stainless Steel	Stainless Steel	Stainless Steel	Stainless Steel	Stainless Steel
CHAMBER DIMENSION (mm)	385×282×100	440×420×140	530×525×140	606×806×190	606×1106×190
MACHINE SIZE PACKING SIZE (cm)	48×33×36 62×49×50	48×54×101 61×67×115	65×58×101 71×75×117	89×72×101 105×87×124	119×72×101 123×87×124
NET/ GROSS WEIGHT (Kg)	35 40	93 115	111 145	199 235	207 248

VACUUM SEALER

DOUBLE CHAMBER

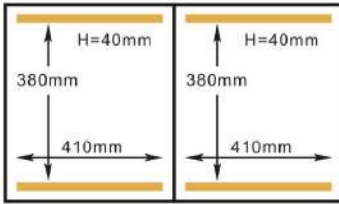

DZ-410/2SA

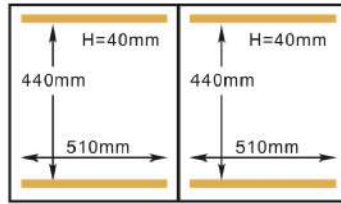

DZ-510/2SA

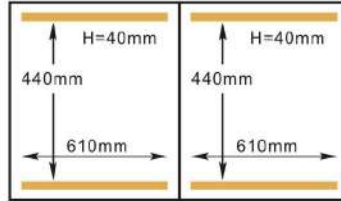

DZ-610/2SA



MODEL	VOLTAGE (V)	MOTOR POWER (W)	SEALING POWER (W)	SEALING LENGTH (mm)	SEALING WIDTH (mm)	CHAMBER DIMENSION (mm)	MACHINE SIZE PACKING SIZE	NET / GROSS WEIGHT
DZ-410/2SA	220V	900	500	410	10	510×500×160	107×69×94 cm 123×79×109 cm	176 kg 216 kg
DZ-510/2SA	380V	1800	600	510	10	610×550×160	127×74×94 cm 142×81×109 cm	215 kg 257 kg
DZ-610/2SA	380V	1800	1000	610	10	720×550×160	149×74×94 cm 162×84×109 cm	257 kg 318 kg

EXTERNAL VACUUM

• Available Option :

- **Helix Filter**
(Untuk produk partikel kecil)
- **Double Seal**
(Untuk plastik kemasan tebal)
- **100 cm Seal width**
(Untuk plastik kemasan lebar)
- **Stainless Body**
(Untuk produk korosif)

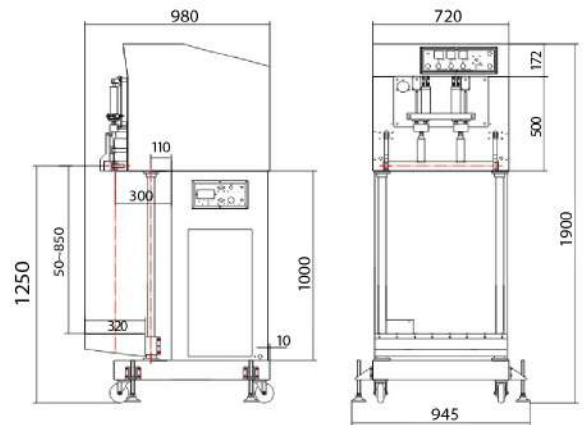

MODEL	VOLTAGE (V/Hz)	MOTOR POWER (W)	SEALING POWER (W)	AIR COMPRESSOR POWER (W)	DISTANT FROM SEALING CENTER TO FLOOR (mm)
DZQ-800L	AC 380V	900	600	1100	1250

SEALING LENGTH (mm)	SEALING WIDTH (mm)	FILM THICKNESS (mm)	VACUUM PUMP RATE (m ³ /h)	MACHINE SIZE PACKING SIZE (cm)	NET / GROSS WEIGHT (kg)
800	10	≤ 0.18	20	80×90×190 99×105×205	255 318

MAXPAX VACUUM SEALER

SINGLE CHAMBER



DZ-260X



DZ-400X



DZ-500X



MODEL	MOTOR POWER (W)	VACUUM PRESSURE (Kpa)	SEALING LENGTH (mm)	SEALING WIDTH (mm)	CHAMBER DIMENSION (mm)	MACHINE SIZE / PACKING SIZE (mm)	NET / GROSS WEIGHT (kg)
DZ-260X	370	1.0	260	10	260×340×110	580×430×440	34 / 36
DZ-400X	900	1.0	400	10	400×330×120	640×560×550	68 / 75
DZ-500X	900	1.0	500	10	500×400×130	75×70×1090	100 / 113

DOUBLE CHAMBER



MODEL	VOLTAGE (V)	MOTOR POWER (W)	SEALING LENGTH (mm)	SEALING WIDTH (mm)	CHAMBER DIMENSION (mm)	PACKING SIZE (cm)	NET / GROSS WEIGHT
DZ-410/2X	220V	900	400	10	400×350×150	107×77×104	134 kg / 156 kg
DZ-510/2X	380V	1500	500	10	500×410×150	137×77×104	188 kg / 215 kg
DZ-610/2X	380V	1500	600	10	600×410×150	154×77×104	208 kg / 237 kg

CARTON SEALER

FXJ SERIES



Top & Bottom Guiding Belt



Top & Bottom Adhesive Tape



FXJ-6050A
Top & Bottom Drive Belt



FXJ-5050AS
Side Drive Belt



MODEL	POWER (W)	MAX. CARTON SIZE (wxh mm)	MIN. CARTON SIZE (wxh mm)	SPEED (m/min)	MAX OUTPUT (carton/min)	HEIGHT OF TABLE (mm)	MACHINE/ PACKING SIZE (cm)	NET/GROSS WEIGHT (kg)
FXJ-6050	200	500×600	180×130	20	30	635-780	176×80×(96-161) 102×85×115	150 175
FXJ-5050AS	200	500×500	80×90	20	30	580-780	175×88×(130-150) 100×98×110	163 187

AUTO FOLD & SEAL



Lower Tape Dispenser



Upper Tape Dispenser



Carton Flap Folder



MODEL	POWER (W)	AIR COMPRESSOR (mpa)	SPEED (m/min)	MAX. CARTON SIZE (L×w×h)(mm)
FXJ-5050Z	260	0.4-0.6	22 (25 carton/min)	600×500×500
MIN. CARTON SIZE (l×w×h)(mm)	WIDTH OF ADHESIVE TAPE (in)	HEIGHT OF TABLE (mm)	MACHINE/ PACKING SIZE (cm)	NET WEIGHT GROSS WEIGHT (kg)
180×160×180	2" , 3"	600-750	1830×920 (1450-1600) 199×112×183	250 368

STRAPPING MACHINE

SEMI AUTO



TP-8022



KZB-I



KZB-II



MODEL	BODY TYPE	POWER (watt)	MIN. STRAPPING SIZE (mm)	HEIGHT OF TABLE (mm)	WIDTH OF STRAP USED (mm)	MACHINE SIZE PACKING SIZE (cm)	NET / GROSS WEIGHT (kg)
TP-8022	Open Type	320	60 × 30	750	6-15 (adjustable)	90 × 58 × 75 92 × 60 × 86	95 100
KZB-I	Closed Type	320	60 × 30	750	6-15 (adjustable)	90 × 58 × 75 92 × 60 × 85	100 110
KZB-II	Low Type	320	60 × 30	500	6-15 (adjustable)	145 × 58 × 51 92 × 60 × 62	90 100

FULL AUTO



PLC Controller



Sensor Equipped Roller



- Easy to install
- PLC controller
- Proximity switch
- Sensor equipped roller
- New die cast heater



Sensor Equipped Roller



MODEL	POWER (W)	MAX.STRAP SIZE (L×H) (mm)	STRAP SPEED (sec/cycle)	STRAP FORCE (V/Hz) (N)	WIDTH OF STRAP USED (mm)	HEIGHT OF TABLE (mm)	MACHINE SIZE PACKING SIZE (cm)	NET / GROSS WEIGHT (kg)
KZ-8060/D	1000	800 × 600	≤ 2.5	25-700 (Adjustable)	9-15	750	140×62×147 155×82×110	240 / 250

SHRINK MACHINE

BS SERIES



BS-2020



- Tinggi tunnel yang dapat diatur manual
- Sistem penggunaan yang sederhana.
- Konstruksi rangka besi.
- Warm-Up Time cepat.
- Konveyor roll atau mesh yang berkualitas.
- Pengatur kecepatan konveyor digital.
- Kecepatan Conveyor 0-10 m / min.
- Kontrol suhu udara 0 ° hingga 200 ° C.
- Pilihan jenis conveyor Mesh atau Roller.

MORE DETAIL



MODEL	VOLTAGE (V/Hz)	POWER (KW)	LOADING (Kg)	SPEED (M/min)	TUNNEL DIMENSION (cm)	MACHINE SIZE PACKING SIZE (cm)	NET / GROSS WEIGHT (kg)
BS-2020	220V	3.6	5	0-10	60×20×20	100×60×120 124×69×78	70 / 90
BS-3020A	220V/380V (Single/three phase)	5.1	10	0-10	90×30×(5-20)	120×50×105 123×56×56	60 / 90
BS-4525A	220V/380V (Single/three phase)	6.5	10	0-10	90×45×(5-25)	120×50×110 124×75×57	90 / 106
BS-4535LA	380V	9.6	30	0-10	120×45×(5-35)	160×65×120 165×75×57	120 / 150
BS-6535LA	380V	9.6	30	0-10	120×65×(5-35)	160×85×120 165×95×68	150 / 185

BS-5540 SERIES



Steel Mesh



Dual Heating Fan



Control Panel



MORE DETAIL



MODEL	VOLTAGE (V/Hz)	POWER (KW)	LOADING (Kg)	CONVEYING SPEED (M/min)	TUNNEL SIZE (cm)	MACHINE SIZE PACKING SIZE (cm)	NET / GROSS WEIGHT (kg)
BS-5540M	380V (3 phase)	23	40	0-8	145×55×40	255×85×160 268×100×112	300 / 426
BS-5540L	380V (3 phase)	27	80	0-10	200×55×40	310×85×160 322×97×106	400 / 522

SHRINK HOOD MACHINE

BSF-5540



- There is an adjustable packing table to accommodate different pack sizes.
- The adjustable film rack can accommodate different widths of film up to 500 mm.
- There are easy to use controls for adjusting L-Sealer time, shrink temperature and shrink time.
- This manually operated machine uses an electro magnetic closer to hold down the chamber hood
- It suitable for all kinds of shrink films such as PVC, POF, PP etc.
- Equipped with lockable casters.



High Quality Material Circulating Heat Fan



MODEL	POWER (W)	CAPACITY (Pcs/h)	MAX. PACKING SIZE (L×W×H) (cm)	MAX. SEALING & CUTTING SIZE (L×H) (cm)	MACHINE SIZE PACKING SIZE	NET WEIGHT GROSS WEIGHT
BSF-5540	4	500-800	W+H <50 W <38, L<50, H<10	55×40	138 × 69 × 107 cm 134 × 87 × 78 cm	125 kg 164 kg

BSF-5640LG

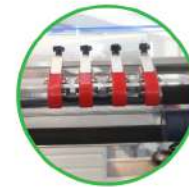

MODEL	POWER (Kw)	AIR PRESSURE REQ. (kg/cm ³)v	CAPACITY (pcs/min)	MAX. PACKING SIZE (cm)	MAX. SEALING & CUTTING SIZE (cm)	MACHINE SIZE PACKING SIZE	NET WEIGHT GROSS WEIGHT
BSF-5640LG	1.8	6-8	0-25	W+H<45, W<40, H<12, L<35	50 × 40	77 × 83 × 160 cm 197 × 112 × 183 cm	300 kg 400 kg

SEAL CUTTING MACHINE

BSF SERIES

L Seal Cutter BSF-501 adalah alat bantu yang ideal untuk mesin shrink tunnel. Alat ini juga dapat digunakan secara terpisah untuk memotong shrink film menurut ukuran yang diinginkan.



Heat Element

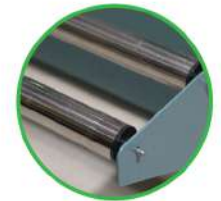

Plastic Roll Holder

MORE DETAIL



MODEL	POWER (W)	MAX. SEALING AREA (L×H) (mm)	ADJUSTABLE HEATING TIME (secs)	MACHINE/ PACKING SIZE (cm)	NET/GROSS WEIGHT (kg)
BSF-501	1000	500 × 350	0~2	95 × 55 × 37 75 × 60 × 35	26 / 28

BSL-5045L

- Alchrome wire sealing and cutting system provides a strong seal.
- The height of sealing table is adjustable.
- Protection device is assembled in sealing frame.
- Excellent perforation designed allows pin changed easily.
- Dual Magnet Hold Down
- Pin Wheel Hole Punch
- Discharge Conveyor Timer
- Locking Casters
- Powder Coated Frame
- Film Roll Guides
- Recommended Film: tOF /PVC /PP



Sealing Handle



Control Panel

MORE DETAIL



MODEL	POWER (W)	CAPACITY (Pcs/h)	MAX. PACKING SIZE (L×W×H) (cm)	MAX. SEALING & CUTTING SIZE (L×H) (cm)	MACHINE SIZE PACKING SIZE	NET WEIGHT GROSS WEIGHT
BSL-5045L	1.2	800-1200	W+H <45 W <40	50×45	156 × 76 × 104 cm 132 × 83 × 110 cm	125 kg 185 kg

SLEEVE SEAL CUTTING MACHINE

MANUAL - SERIES



TF-6540SA
SEMI AUTO- FRONT FEED



BSF-6030XI
AUTOMATIC - SIDE FEED
FOR BOTTLE

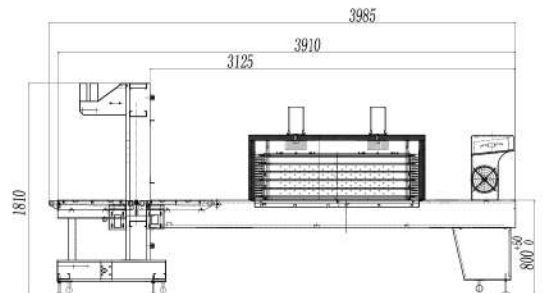

BSF-6540XLT (SEMI AUTO)
BSF-6540XLT III (FULL AUTO)



MODEL	POWER (kw)	MAX. PACKING SIZE (cm)	MAX. SEALING LENGTH (cm)	MACHINE SIZE (cm)	NET WEIGHT (kg)
TF-6540SA	1.5	55 × 40 × 38	65	93 × 104 × 192	300
BSF-6030XI	2	50 × 30 × 33	70×33	136 × 212 × 190	465
BSF-6540XLT	18.5	52 × 32 × 35	60	350 × 86 × 200	520
BSF-6540XLT-III	18.5	∞ × 50 × 30	62	400 × 106 × 182	580

CODING MACHINE

CODING SERIES



**DY-8
MANUAL**



**HP-280
SEMI AUTOMATIC**



**MY-380F/W
AUTOMATIC**



MODEL	DY-8	HP-280	MY-380F/W
POWER (w)	50	150	180
PRINTING LINE	2x4 size, 3 lines (Max. 12 characters/line. 5 lines is available to be customized)		T type (10.5PT):11 lines (Max.10 characters/line) R type (10.5PT):8 lines (Max.11 characters/line)
RIBBON SIZE (mm)	25 / 30 / 35 (width)		
SOLID INK ROLLER (mm)	-	-	35x32
PRINTING SPEED (pcs/min)	-	-	≤300
OBJECT SIZE (mm)	-	-	L:50-550 W:30-300
PRINTING SIZE (mm) TYPE SIZE (mm)	-	-	Single side 60-250 2.5x1.5(8PT) 2x2.5(9PT) 3x2(10.5PT) 5x2.5(18PT)
MACHINE SIZE (cm) PACKING SIZE (cm)	27 × 16 × 22 29 × 20 × 27	23 × 23 × 33 33 × 30 × 38	44 × 47 × 26 53 × 52 × 34
NET WEIGHT (kg) GROSS WEIGHT (kg)	2 3	6 7.5	26 27

LASER CODING



MODEL	SP-200
PRINTABLE IMAGES	Alphanumeric, Logo, Date/Time, Expiry Date, Shift Code, Lot-Box Code and Barcode, Counter
PRINTABLE LINES & HEIGHTS	1,2,3,4 lines. Total Line height is limited to 12.7 mm
HEIGHTS	2.7/3.6/5.5/8/10/12.7 mm (0.11"/0.14"/0.22"/0.31"/0.39"/0.5")
PRINT SPEED	60 meters (148 feet)/minute at 300dpi horizontal resolution
MACHINE SIZE (cm) PACKING SIZE (cm)	12 × 14 × 19 27 × 16 × 23
NET WEIGHT (kg) GROSS WEIGHT (kg)	0.81 kg (include cartridge) 2 kg

INDUCTION SEALER

DGYF & LGYF SERIES



DGYF-S500A | DGYF-S500C
MANUAL



LGYF-1500A-I Painted Body
LGYF-1500A-II Stainless Steel Body



MODEL	DGYF-S500A	DGYF-S500C	LGYF-1500A
POWER (w)	500 watt	600 watt	1500
SEALING DIAMETER (cm)	Ø2cm-Ø10 cm	Ø6cm -Ø13 cm	Ø2cm - Ø5 cm
SEALING SPEED (m/minute)	-	-	3-10
PRODUCTION CAPACITY (pcs/minute)	-	-	250
AVAILABLE HEIGHT (cm)	-	-	4-20
MACHINE SIZE (cm) PACKING SIZE (cm)	34 × 29 × 15 47 × 39 × 18	34 × 29 × 15 48 × 39 × 18	115 × 48 × 40 96 × 56 × 46
NET WEIGHT (kg) GROSS WEIGHT (kg)	4 5	4 5	3 8

MODEL	HL-3000A
POWER (watt)	3000
SEAL DIAMETER (mm)	Ø15-60 or Ø50-121
SEALING SPEED (Bottles/m)	0-300
SIZE FOR MAIN BODY (cm)	180 × 42 × 145
MACHINE SIZE (cm) PACKING SIZE (cm)	132 × 70 × 67 174 × 87 × 77
NET WEIGHT (kg) GROSS WEIGHT (kg)	130 170



HL-3000A continuous induction sealing machine is applicable to seal plastic container or glass container made of any kind of material.

PISTON FILLING

LIQUID SERIES



SINGLE NOZZLE



DOUBLE NOZZLE

MODEL	LPF-300T	LPF-500T	LPF-1000T	LPF-2500T	LPF-5000T
FILLING RANGE (ml)	100-300	50-500	100-1000	500-2500	1000-5000
EXTERNAL DIMENSIONS (L×W×H) (cm)	97 × 38 × 38 (1 head) 97 × 50 × 38 (2 head)	97 × 38 × 38 (1 head) 97 × 50 × 38 (2 head)	115 × 38 × 38 (1 head) 115 × 45 × 38 (2 head)	125 × 45 × 40 (1 head) 125 × 65 × 40 (2 head)	130 × 45 × 50 (1 head) 130 × 75 × 50 (2 head)
NET WEIGHT (kg)	23 kg (1 head) 28 kg (2 head)	25 kg (1 head) 30 kg (2 head)	28 kg (1 head) 35 kg (2 head)	52 kg (1 head) 65 kg (2 head)	55 kg (1 head) 98 kg (2 head)

PASTE SERIES



SINGLE NOZZLE



DOUBLE NOZZLE

MODEL	PPF-300T	PPF-500T	PPF-1000T	PPF-2500T	PPF-5000T
FILLING RANGE (ml)	100-300	50-500	100-1000	500-2500	1000-5000
EXTERNAL DIMENSIONS (L×W×H) (cm)	97 × 38 × 38 (1 head) 97 × 50 × 38 (2 head)	97 × 38 × 38 (1 head) 97 × 50 × 38 (2 head)	115 × 38 × 38 (1 head) 115 × 45 × 38 (2 head)	125 × 45 × 40 (1 head) 125 × 65 × 40 (2 head)	130 × 45 × 50 (1 head) 130 × 75 × 50 (2 head)
NET WEIGHT (kg)	23 kg (1 head) 28 kg (2 head)	25 kg (1 head) 30 kg (2 head)	28 kg (1 head) 35 kg (2 head)	52 kg (1 head) 65 kg (2 head)	55 kg (1 head) 98 kg (2 head)

FILLING MACHINE

LPF SERIES

MODEL	A03
MATERIAL OF MACHINE	Stainless steel 304
FILLING RANGE (ml)	5-50
CAPACITY OF HOPPER (kg)	10
FILLING ACCURACY (ml)	± 0.2-1
FILLING SPEED (times/min)	20-60
WORKING PRESSURE (mpa)	0.4-0.6
HOPPER CAPACITY (liters)	10
MACHINE SIZE (cm) PACKING SIZE (cm)	29 × 29 × 72 34 × 34 × 79
NET WEIGHT (kg) GROSS WEIGHT (kg)	11 12



Piston



Liquid Outlet

MORE DETAIL



LPF SERIES



MORE DETAIL



2 LINE & 4 LINE
PNEUMATIC &
PC CONTROLLER

MODEL	2 LINE	4 LINE	8 LINE	16 LINE
POWER (kw)	3.5	5.5	8	22
VOLTAGE (v)	380	380	380	380
CAPACITY	2000-2200	3800-4000	7000-8000	14000-16000
SEALING WIDTH (mm)	190	350	360 Double	700 Double
MACHINE SIZE (cm) PACKING SIZE (cm)	220 × 50 × 150 230 × 67 × 170	300 × 80 × 170 310 × 100 × 185	400 × 80 × 170 420 × 100 × 185	400 × 130 × 170 420 × 140 × 185
NET WEIGHT (kg) GROSS WEIGHT(kg)	500 700	700 800	1000 1200	1300 1500

FILLING WEIGHING

FZ- SERIES



FZ-200
AUTOMATIC



FZ-999



FZS-100TSS



FZS-100

MORE DETAIL



MODEL	POWER (W)	FILLING WEIGHT (gr)	*FILLING ACCURACY (gr)	*FILLING SPEED	BAG SIZE (W x L) (mm)	MACHINE SIZE (P x L x T) (cm)	WEIGHT (kg)
FZ-200	15	2-200	+0.3	10-25 pcs/min	-	38 x 32 x 52	10
FZ-500	15	10-500	+2	10-25 pcs/min	-	38 x 32 x 52	10
FZ-999	80	25-2000	+2	10-20 pcs/min	-	40 x 30 x 96	33
FZS-100TSS	500	1-100	+2	12-15 pcs/min	0-80 ; 0-150 3 side seal	43 x 51 x 140	55
FZS-100BS	500	1-100	+2	12-15 pcs/min	0-80 ; 0-150 back seal	43 x 51 x 140	55
FZS-500TSS	500	50-500	+2	12-15 pcs/min	0-190 ; 0-220 3 side seal	43 x 51 x 140	55
FZS-500BS	500	50-500	+2	12-15 pcs/min	0-190 ; 0-220 back seal	43 x 51 x 140	55

*Filling Accuracy depending on material

*Filling Speed depending on materials and different aliquots weight

VERTICAL FILLING

DXDZ SERIES



DXDK Series
(for Granule)



DXDF Series
(for Powder)



DXDG Series
(for Paste)



DXDY Series
(for Liquid)



DXDC Series
(for Tea)

MODEL	POWER (W)	CAPACITY (BAGS/MIN)	PACKING CAPACITY (ML)	LENGTH OF BAG (MM)	WIDTH OF BAG (MM)	MACHINE SIZE (L×W×H) (CM)	NET WEIGHT (KG)
DXDK-40II	1700	50-80	5-40	50-110	30-80	79 × 60 × 178	350
DXDK-150II	1700	35-75	30-150	80-150	30-110	79 × 60 × 178	360
DXDK-500II	1700	15-70	20-500	50-220	30-150	115 × 86 × 185	370
DXDK-1000II	2000	15-50	50-1000	50-250	50-200	115 × 86 × 207	380
DXDF-20AX	1300	35-55	2-20	35-110	25-80	106 × 72 × 180	330
DXDF-50AX	1500	25-50	5-50	80-150	70-100	106 × 72 × 180	340
DXDF-100AX	1700	20-40	10-100	50-200	50-150	113 × 86 × 195	375
DXDF-500AX	2200	15-30	100-500	50-270	50-150	126 × 86 × 207	380
DXDG-20II	1700	5-20	50-80	50-110	30-90	79 × 60 × 178	350
DXDG-50II	1700	10-50	40-70	80-150	30-110	79 × 60 × 178	350
DXDG-100II	1700	20-100	30-60	80-220	30-150	79 × 60 × 178	400
DXDG-500II	1750	50-500	30-60	50-220	30-150	112 × 90 × 195	480
DXDY-1000AII	1200	1500-2100	200-500	240-320	(50-170)×(50-150)	85 × 75 × 160	350
DXDC-125	1300	35-70	1.5-40	50-110	30-80	93 × 72 × 185	280

*Thread Length 160 mm (DXDC-125)

HORIZONTAL WRAPPER

HORIZONTAL WRAPPER

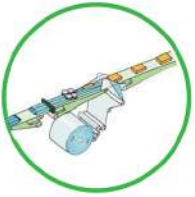

X - Down Film Pillow Packaging Machine

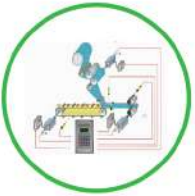

No X - Top Film Pillow Packaging Machine



MORE DETAIL



MODEL	DXDZ-280	DXDZ-280X	DXDZ-350	DXDZ-350X	DXDZ-450	DXDZ-450X
POWER (Kw)	2.5		2.5		2.5	
FILM WIDTH (mm)	Max.280		Max.350		Max.500	
BAG LENGTH (mm)	60-280		80-350		80-350	
BAG WIDTH (mm)	10-100	20-100	30-120		30-180	
PRODUCT HEIGHT (mm)	Max.40		Max.60		Max.80	
FILM ROLL DIAMETER (mm)	Max.360		Max.360		Max.360	
PACKAGING SPEED (bags/min)	30-200		10-180		10-150	
MACHINE SIZE (L×W×H) (mm)	4790×700×1520	3870×700×1520	4700×800×1550	4800×800×1520	5320×1020×1520	4800×800×1520
MACHINE WEIGHT (kg)	500		500		600	

PALLET WRAPPER

PALLET WRAPPER



INTELLIGENT TOUCH CONTROL

XOPS



TOP PRESSURE

X3



SIEMENS PLC

X1



AUTOMATIC CUT AND CLAMP FILM

X100



MODEL	POWER (Kw)	COLUMN HEIGHT (cm)	PACKING HEIGHT (cm)	TURNTABLE SIZE (cm)	TURNTABLE HEIGHT (mm)	LOAD WEIGHT (kg)	FILM WIDTH (mm)	MACHINE SIZE & WEIGHT (cm) (kg)
XOPS	0.75	280	240	165	87	1500	500	233 × 150 × 240 550
X1	0.75	265	240	165	87	2000	500	280 × 180 × 265 800
X100	1.5	265	240	165	87	2000	500	280 × 165 × 275 680
X3	0.75	265	240	165	87	2000	500	280 × 180 × 265 800
X300	1.5	265	240	165	87	2000	500	280 × 165 × 275 680

SKIN & BLISTER MACHINE

TB-390

Skin packaging machines are easy to operate and can pack all kind of products without adoption of moulds. The packed goods are transparent, beautiful, with strong stereoscopic impression and even can be protected from damp and dust.

Features

- Rugged All Metal Construction
- Powerful Heat Oven
- Infrared Heating Elements for Quick and Uniform Heating
- Electronic Frame Movement (Oven to Vacuum & Vice Versa)
- Free Rolling Roll Holder
- Double Oil Filled Vacuum Pump



Roll Holder



Powerful Heater

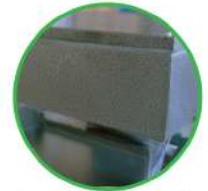

Metal Construction



MODEL	VOLTAGE (V)	TOTAL POWER (kw)	PACKAGING AREA (mm)	PACKING SPEED (pcs/h)	PACKAGE MATERIAL	FILM WIDTH (mm)	MACHINE SIZE PACKING SIZE (cm)	NET/GROSS WEIGHT (Kg)
TB-390	380 V (3 phase)	7.5	390 × 540	50~60	PVC / PE Skin Packaging Film	450	152 × 61 × 136 100 × 69 × 149	135 / 172

XBF-500



XBF-500 is applicable to combined paper cards and plastic sheets, such as PVC, PE and PP. It is easy to operate and does not require operator training. It can be used to package toys, stationary, small size tools, among other products in a blister shape

MODEL	XBF-500
VOLTAGE (v)	AC 220
SEALING POWER (w)	1500
PRESSURE BOARD AREA (mm)	500 × 300
TURNTABLE DIAMETER	φ1000
MAX PACKAGE HEIGHT (mm)	150
MAX CONVEYOR LOADING (kg)	110
MACHINE SIZE (cm) PACKING SIZE (cm)	92 × 107 × 152 85 × 59 × 164
NET WEIGHT (kg) GROSS WEIGHT (kg)	70 100

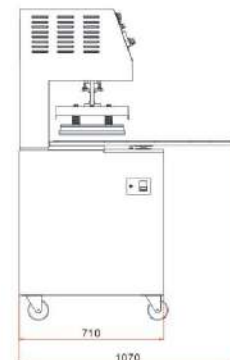
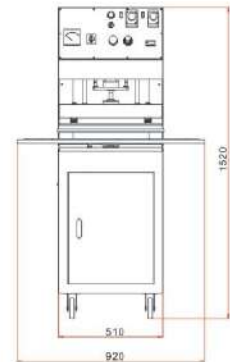

CAPPING & LABELING MACHINE

CAPPING



DK-50Z
Plastic Cap

DK-50/D
Metal Cap



MODEL	POWER (Kw)	CAP DIAMETER (mm)	APPLICABLE BOTTLE HEIGHT (mm)	MACHINE SIZE PACKING SIZE (cm)	NET / GROSS WEIGHT (kg)
DK-50/D	0.37	φ2-φ4	10-30	35×25×65 60×26×99	65 / 70
DK-50Z	0.37	φ2.5-φ4	5-32	65×20×92 60×26×99	65 / 70

LABELING



MODEL	MT-50		
POWER (w)	120	BOTTLE DIAMETER (mm)	20-120
LABELING SPEED (pcs/min)	10-40	LABEL SIZE (mm)	≤ 150 × 230
LABELING ACCURACY (mm)	0.5	MAX EXTERNAL ROLL DIAMETER (mm)	250
MACHINE SIZE (mm) PACKING SIZE (mm)	65 × 40 × 50 66 × 36 × 47	MAX INTERNAL ROLL DIAMETER (mm)	75
NET WEIGHT (kg)	30	GROSS WEIGHT (kg)	31

FOLDING



MODEL	ZE-8B/4	
POWER (w)	80 watt	
FOLDING TRAY NUMBER	4	
MAX. PAPER SIZE (mm) MIN. PAPER SIZE (mm)	315 × 1225 50 × 70	
PAPER THICKNESS (gr)	40 - 125	
MACHINE SIZE (cm) PACKING SIZE (cm)	108 × 53 × 58 64 × 56 × 64	
NET WEIGHT (kg) GROSS WEIGHT (kg)	48 53	

PLASTIC PACKAGING

FOOD PACKAGING

VACUUM BAG POLOS				IKAN	EMBOSED
10 x 6 cm	15 x 20 cm	18 x 30 cm	25 x 30 cm	12 x 30 cm	15 x 20 cm
10 x 20 cm	15 x 25 cm	18 x 35 cm	30 x 35 cm	13 x 36 cm	16 x 25 cm
11 x 16 cm	16 x 25 cm	20 x 25 cm	30 x 40 cm	15 x 30 cm	18 x 28 cm
12 x 11 cm	17 x 22 cm	20 x 30 cm	30 x 45 cm	15 x 45 cm	20 x 30 cm
13 x 21 cm	18 x 28 cm	23 x 34 cm	30 x 50 cm	18 x 35 cm	23 x 34 cm



Plastik
Vacuum
PE + Nylon 75 micron

NON ZIPPER	WITH ZIPPER
12 x 20 cm	12 x 20 cm
14 x 20 cm	14 x 22 cm
14 x 25 cm	16 x 24 cm
16 x 26 cm	
22 x 30 cm	



Stand Up
Nylon
PE + Nylon 140 micron

NON ZIPPER	WITH ZIPPER
10 x 16 cm	12 x 20 cm
12 x 20 cm	14 x 24 cm
14 x 24 cm	14 x 26 cm
16 x 24 cm	16 x 29 cm
16 x 27 cm	



Plastik
Kombinasi
OPP METALIZE 90 mic

INDUSTRIAL PACKAGING

POF SHRINK	LEBAR ROLL : 7 - 13 inch
	KETEBALAN : 15 - 19 micron
PVC SHRINK	LEBAR ROLL : 7-12 cm /13-19 cm
	POTONG : ROLL/KANTONG/LENGKUNG
PE SHRINK	LEBAR ROLL DIATAS 30 cm
	LEBAR ROLL DIBAWAH 30 cm



POF PVC PE
SHRINK

PE SHRINK	LEBAR ROLL DIATAS 30 cm
	LEBAR ROLL DIBAWAH 30 cm

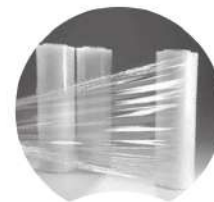

**STRECH
FILM**

PE SHRINK	LEBAR ROLL DIATAS 30 cm
	LEBAR ROLL DIBAWAH 30 cm



**STRAPPING
BAND**



WIRASTAR



ICE MACHINE



RTW-160L

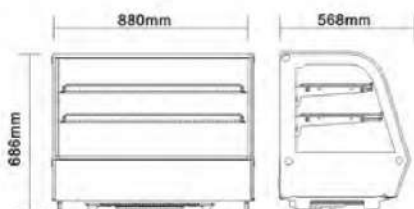

MODEL	POWER (w)	CAPACITY (liter/h)	TEMPERATURE (°c)	MACHINE SIZE PACKING SIZE (cm)	NET / GROSS WEIGHT (kg)
RTW-160L	250	160	0-12	88 × 57 × 69 95 × 63 × 74	66 / 70

ICE CREAM MACHINE

SOFT ICE CREAM SERIES

Mesin Es Krim adalah mesin yang digunakan untuk membuat es krim yang disukai oleh banyak orang dengan berbagai rasa dan variasi. Dengan mesin pembuat es krim otomatis, anda bisa membuat ice cream lebih cepat, efisien dan hemat.



WIR-818T
Table Top



WIR-818F
Standing



MODEL	POWER (w)	CAPACITY (liter/h)	FLAVOUR	HOPPER (liter)	FREEZING tank (liter)	MACHINE SIZE PACKING SIZE (cm)	NET / GROSS WEIGHT
WIR-818T	1800	18	2 Flavour +1 Mix	2 x 4.5	2 x 1.7	52 x 70 x 68 55 x 73 x 75	90 / 97
WIR-818F	1800	18	2 Flavour +1 Mix	2 x 4.5	2 x 1.8	54 x 57 x 137 58 x 62 x 142	119 / 124

HARD ICE CREAM SERIES



MODEL	WIR-128Y
POWER (w)	1400 W
FLAVOUR	1 Flavour
CAPACITY (liter/h)	25 l/Hour
REFRIGERANT	R404a
MACHINE SIZE (cm) PACKING SIZE (cm)	53 x 53 x 83 cm 70 x 57 x 86 cm
NET WEIGHT (kg) GROSS WEIGHT (kg)	80kg 91 kg



ICE CUBE MACHINE

ICB SERIES

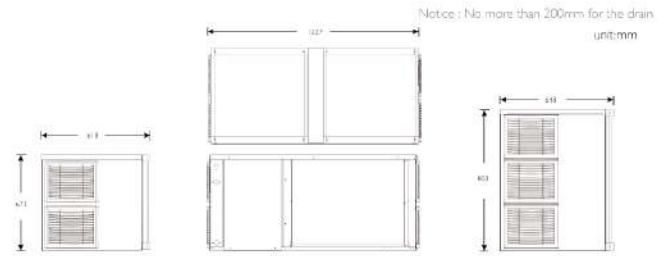
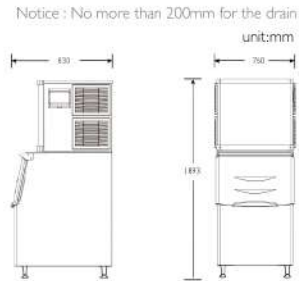

ICB-12



ICB-280P



ICB-350P | ICB-1000P



ICB-2000P

MODEL	ICB-12	ICB-280P	ICB-350P	ICB-1000P	ICB-2000P
POWER (watt)	850	850	1000	2300	3800
MAXIMAL DAILY OUTPUT (kg)	12	127	160	455	909
BIN CAPACITY (kg)	0.7	36	125	125	315
REFRIGERANT	R600A	R404A	R404A	R404A	R404A
NET MACHINE SIZE (cm)	22×31×32	66×69×92	56×83×172	76×83×190	123×97×205
NET MACHINE WEIGHT (kg)	7	60	50	85	150
NET BIN WEIGHT (kg)	-	-	35	45	70
PACKING SIZE MAIN MACHINE (cm) & WEIGHT (kg)	26×33×37 8	78×75×90 67	66×75×62 54	85×70×81 90	136×77×87 170
PACKING SIZE OF BIN (cm) & WEIGHT (kg)	- -	- -	65×89×106 40	85×89×106 50	104×131×129 100

ICE MACHINE

JUICE DISPENSER



Stainless Steel Dispenser



Waste Hose



AJ Type: Mixing



A Type: Spraying



MODEL	POWER (W)	CAPACITY (liter)	TEMPERATURE (°C)	TYPE	MACHINE SIZE PACKING SIZE (cm)	NET / GROSS WEIGHT (kg)
JCD-115	120	15	7-12	A : Spraying AJ : Mixing	28 × 45 × 67 28 × 50 × 73	17 / 20
JCD-230	250	2 × 15	7-12	A : Spraying AJ : Mixing	41 × 45 × 67 46 × 50 × 74	26 / 31
JCD-345	370	3 × 15	7-12	A : Spraying AJ : Mixing	61 × 45 × 67 67 × 50 × 74	34 / 40

ICE CRUSHER



Ice Grinding Setting



Switch ON/OFF/REVERSE

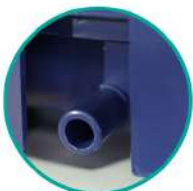

Water Drain Hole



Stainless Blade



- Memakai ice cube / ice tube.
- Mesin untuk membuat es serut.
- Getaran dan suara lebih halus.
- Membuat Es Campur.
- Kehalusan es bisa di atur.
- Memakai ice cube/ice tube hasil es agak kasar, cocok untuk Es Teler, Es Doger.



MODEL	POWER (w)	VOLTAGE (v)	ROTATION SPEED (rpm)	EFFICIENCY (kg/h)	MACHINE SIZE PACKING SIZE (cm)	NET / GROSS WEIGHT (kg)
ICH-168	250	220	350	120	29 × 37 × 44 33 × 44 × 50	12 / 14



MEAT MACHINE

MEATBALL MAKER



5 Size Meatball Moulding



ON/OFF Button



Kuningan Food Grade



MODEL	POWER (W)	OUTPUT (pcs/min)	MOULDING (mm)	SPEED (rpm)	PACKING SIZE (cm)	NET / GROSS WEIGHT (kg)
MBM-300	1100	300	5 pcs (18, 22, 26, 30, 32)	2800	45 × 74 × 137	70 / 91

MEAT MACHINE

MEAT MIXER



Water Tap



Heavy Duty Blade



Ground



Surge Protection

Meatball Mixer adalah salah satu alat yang biasa digunakan bagi para pengusaha atau pebisnis kuliner olahan makanan yang berbahan dasar daging. Mesin tersebut dapat membuat daging jadi halus yang nantinya akan dipergunakan sebagai bahan dasar olehan makanan. Mesin giling daging digunakan oleh pengusaha kuliner kecil hingga pengusaha kuliner besar.



MODEL	POWER (W)	CAPACITY (kg)	BOWL VOLUME (liter)	PACKING SIZE (cm)	NET / GROSS WEIGHT (kg)
MMX-R18	1100	2	4	40 × 38 × 78	24 / 35
MMX-R22	2200	3	8	40 × 42 × 80	32 / 41

BOWL CUTTER



6 High Quality Blade



Food Grade Stainless



Thick Cover



Handle & Safety Cover

Bowl Cutter BCT-20 merupakan salah satu jenis mesin pemotong dan penggiling daging paling modern. Mesin ini mempunyai mesin motor listrik yang besar dengan daya putaran kuat. Mesin ini biasanya digunakan untuk membuat adonan bakso, sosis, dan olahan daging yang dihaluskan lainnya. Mesin ini dapat menampung dan menghaluskan daging dengan jumlah banyak.



MODEL	POWER (w)	CAPACITY (kg/h)	BOWL VOLUME (liter)	SPEED (rpm)	PACKING SIZE (cm)	NET / GROSS WEIGHT (kg)
BCT-20	1500	120	24	1440	100 × 80 × 109	125 / 161

MEAT MACHINE

MEAT SLICER

Semi Automatic Meat Slicer merupakan alat yang digunakan untuk mengiris dan memotong berbagai jenis daging, biasanya daging sapi, dengan menggunakan pisau yang ada di dalamnya sehingga menghasilkan irisan daging yang sesuai dengan kebutuhan.

MORE DETAIL



MSC-220 | MSC-250 | MSC-300



MSC-300D

MODEL	POWER (w)	BLADE DIAMETER (mm)	MATERIAL	SLICE THICKNESS (mm)	MACHINE SIZE PACKING SIZE (cm)	NET / GROSS WEIGHT (kg)
MSC-220	24	220 (8")	Stainless Steel	1 - 12	48 × 41 × 36 57 × 46 × 40	15 / 16
MSC-250	150	250 (10")	Stainless Steel	0.2 - 12	51 × 43 × 38 57 × 46 × 40	15 / 17
MSC-300	250	300 (12")	Stainless Steel	0.2 - 15	60 × 48 × 45 60 × 48 × 48	21 / 22
MSC-300D	550	300 (12")	Stainless Steel	0 - 15	60 × 51 × 75 70 × 61 × 80	65 / 70

BONE SAW



MORE DETAIL



BSW-1650A



BSW-1900A



BSW-2020 | BSW-2400

MODEL	POWER (w)	WHEEL DIAMETER (mm)	SAW LENGTH (mm)	PACKING SIZE (cm)	NET / GROSS WEIGHT (kg)
BSW-1650A	750	210	1650	55 × 57 × 102	36 / 53
BSW-1900A	750	230	1900	65 × 62 × 115	60 / 76
BSW-2020	1500	250	2020	75 × 67 × 175	116 / 148
BSW-2400	2200	300	2400	88 × 82 × 186	146 / 148

MEAT MACHINE

MEAT GRINDER



MGD-88X



MGD A SERIES



MGD H SERIES



MODEL	MGD-88X	MGD-12A	MGD-22A	MGD-8H	MGD-12H	MGD-22H	MGD-32H
POWER (w)	390	850	1100	250	550	750	1100
OUTPUT (kg/h)	60	170	250	80	120	220	320
MACHINE SIZE (cm)	45 × 24 × 20	37 × 22 × 41	59 × 24 × 55	54 × 26 × 42	57 × 26 × 47	65 × 31 × 50	65 × 31 × 50
NET WEIGHT (kg)	4	17	23	15	20	21	27

SAUSAGE MAKER



SSF-SV7



4 Size Sausage Filler



MODEL	SSF-SV5	SSF-SV7
CAPACITY	5 Liter	7 Liter
CYLINDER DIAMETER x L	φ 14 × 32 cm	φ 14 × 46 cm
MATERIAL FULL	stainless steel	stainless steel
PACKING SIZE	69 × 36 × 29 cm	83 × 36 × 35 cm
NET WEIGHT & GROSS WEIGHT	11 kg 12 kg	12 kg 13 kg

BAKERY MACHINE



BAKERY MACHINE

HOME MIXER



Mixer blade

Egg whisk

Dough hook



B-5

AVAILABLE COLOR



B-7

AVAILABLE COLOR



MORE DETAIL



MODEL	POWER (W)	BOWL CAPACITY (liter)	MACHINE SIZE PACKING SIZE (cm)	NET / GROSS WEIGHT (kg)
B-5	300	5	39 × 23 × 33 43 × 26 × 41	4 / 4.6
B-7	350	7	24 × 38 × 44 28 × 44 × 47	21 / 22

DOUGH MIXER

PLANETARY MIXER



A. Spiral



B. Beater



C. Whip



MODEL	POWER (W)	CAPACITY (liter / kg)	SPEED (rpm)	MOTOR	MACHINE SIZE PACKING SIZE (cm)	NET / GROSS WEIGHT (kg)
B-15	370	15l / 3	90/160/300	Gear	41 × 44 × 67 55 × 46 × 80	50 / 60
B-20	750	20l / 8	125/225/404	Gear	42 × 52 × 80 53 × 69 × 100	73 / 83
B-30	1500	30l / 12	110/200/420	Gear	58 × 52 × 82 59 × 67 × 91	70 / 86
B-20F	1100	30l / 4-5	143/234/492	Belt	58 × 44 × 81 58 × 44 × 81	98 / 98
B-30F	1500	30l / 7-8	143/234/492	Belt	61 × 53 × 102 61 × 53 × 102	100 / 100
B-40F	2000	40l / 8-9	143/234/492	Belt	65 × 50 × 104 65 × 50 × 104	130 / 130

SPIRAL MIXER



FITUR :

- Alat pengaduk dan bowl dapat berputar secara bersamaan, searah ataupun berlawanan arah
- Kapasitas lebih besar dengan daya tampung lebih banyak
- Terdapat fungsi timer otomatis
- Produksi adonan jadi lebih berkualitas dan besar



MODEL	POWER (W)	BOWL VOLUME (liter)	MAX CAPACITY (kg)	MIX SPEED (rpm)	BOWL SPEED (rpm)	MACHINE SIZE PACKING SIZE (cm)	NET / GROSS WEIGHT (kg)
BHS-20A	1500	20	8	2 speed 125 & 250	2 speed 12.5 & 25	66 × 49 × 84 76 × 46 × 89	93 / 115
BHS-30A	1500	30	12	2 speed 125 & 250	2 speed 12.5 & 25	72 × 44 × 87 83 × 50 × 97	117 / 142

BAKERY MACHINE

HORIZONTAL MIXER

- Digunakan untuk membuat adonan roti, mie, dan kulit pastel.
- Disarankan menggunakan air dingin atau es untuk hasil yang lebih baik.



Stainless Steel Bowl
(90° Rotation)



MODEL	POWER (kw)	CAPACITY (kg/batch)	SPEED (rpm)	MACHINE SIZE PACKING SIZE (cm)	NET / GROSS WEIGHT (kg)
HMX-15	1.5	15	30	54 × 50 × 67 72 × 55 × 81	90 / 110
HMX-25	2.2	25	30	80 × 50 × 71 88 × 58 × 83	110 / 135

GAS OVEN

- Full Glass Door Panel
- Stainless Steel Outer Body



OVN-20



OVN-40



OVN-60



MODEL	POWER (kw)	TRAY SIZE (cm)	TRAY QUANTITY	MACHINE SIZE PACKING SIZE (cm)	NET / GROSS WEIGHT (kg)
OVN-10	75	40 × 60	1 deck 1 trays	76 × 93 × 66 75 × 94 × 74	57 / 60
OVN-20	100	40 × 60	1 deck 2 trays	139 × 93 × 66 137 × 94 × 74	115 / 125
OVN-40	200	40 × 60	2 deck 4 trays	139 × 93 × 132 137 × 94 × 133	190 / 207
OVN-60	300	40 × 60	3 deck 6 trays	139 × 93 × 174 137 × 94 × 175	270 / 295

BAKERY MACHINE

PROOFER



PRF-16B



PRF-32B



MODEL	POWER (kw)	TRAY SIZE (cm)	TRAY QUANTITY	MACHINE SIZE PACKING SIZE (cm)	NET / GROSS WEIGHT (kg)
PRF-16B	1.6	40 × 60 × 2	1 doors 16 trays	50 × 70 × 202 60 × 80 × 210	55 / 75
PRF-32B	2.8	40 × 60 × 2	2 doors 32 trays	96 × 70 × 202 110 × 80 × 210	85 / 106

BREAD SLICER



31 Blades



Power Switch



Jarak Potong
12mm



Guiding Rod



MODEL	POWER (w)	BREAD LENGTH (mm)	BREAD THICKNESS (mm)	MACHINE SIZE PACKING SIZE (cm)	NET / GROSS WEIGHT (kg)
BSC-31	250	350	12	68 × 78 × 78 82 × 70 × 88	65 / 95

CAFE, HOTEL, RESTAURANT

EQUIPMENT



HOREKA EQUIPMENT

FOOD DEHYDRATOR

MORE DETAIL



FDH-5



FDH-6



FDH-10



FDH-16



FDH-20



FDH-30

MODEL	MAX POWER (w)	WIRE RACK SIZE (cm)	TEMPERATURE (°c)	MACHINE SIZE PACKING SIZE (cm)	NET / GROSS WEIGHT (kg)
FDH-5	230	25 x 32 5 Trays	35-70	32 x 25 x 22 35 x 28 x 25	6 / 8
FDH-6	400	30 x 28 6 Trays	30-90	32 x 39 x 25 44 x 37 x 31	6.6 / 7.5
FDH-10	1000	39 x 28 10 Trays	30-90	40 x 46 x 44 53 x 47 x 49	11 / 14
FDH-16	1500	40 x 38 16 Trays	30-90	52 x 51 x 67 60 x 59 x 71	21 / 25
FDH-20	2000	40 x 38 20 Trays	30-90	55 x 47 x 97 65 x 55 x 98	40 / 45
FDH-30	2400	40 x 38 30 Trays	30-90	57 x 46 x 136 67 x 57 x 136	48 / 52

DISPLAY WARMER



SHW-1P



SHW-2P
AVAILABLE COLOR



SHW-60-1

MORE DETAIL



MODEL	MAX POWER (w)	TEMPERATURE (°c)	MACHINE SIZE PACKING SIZE (cm)	NET / GROSS WEIGHT (kg)
SHW-1P	500	50-85	38 x 46 x 61 48 x 57 x 73	15 / 19
SHW-2P	800	50-85	66 x 46 x 61 77 x 57 x 73	20 / 28
SHW-60-1	1840	30-85	66 x 44 x 65 71 x 53 x 72	20 / 36

HOREKA EQUIPMENT

ELECTRIC FRYER



FRY-E81



FRY-E82

MODEL	POWER (kw)	CAPACITY (liter)	MACHINE SIZE PACKING SIZE (cm)	NET / GROSS WEIGHT (kg)
FRY-E81	2.5	6	31 × 47 × 33 32 × 47 × 37	17 / 20
FRY-E82	5	2 × 6	59 × 47 × 33 59 × 48 × 34	26 / 31

GAS FRYER



FRY-G71



FRY-G72



FRY-G171



FRY-G172

MODEL	POWER	CAPACITY (liter)	MACHINE SIZE PACKING SIZE (cm)	NET / GROSS WEIGHT (kg)
FRY-G71	GAS	6	47 × 30 × 45 58 × 55 × 50	9 / 10
FRY-G72	GAS	2 × 6	56 × 47 × 45 58 × 55 × 50	14 / 17
FRY-G171	GAS	17	34 × 65 × 67 42 × 83 × 70	25 / 30
FRY-G172	GAS	2 × 17	68 × 65 × 67 84 × 83 × 70	32 / 40

HOREKA EQUIPMENT

GAS GRIDDLE



GRD-718



GRD-720



GRD-722



Half Grooved



Exhaust



Waste Basket



MODEL	POWER	MATERIAL	PLATE	MACHINE SIZE PACKING SIZE (cm)	NET / GROSS WEIGHT (kg)
GRD-718	GAS	Stainless Steel	Flat	55 × 46 × 34 62 × 53 × 23	16 / 17
GRD-720	GAS	Stainless Steel	Flat	73 × 53 × 34 78 × 55 × 24	25 / 26
GRD-722	GAS	Stainless Steel	HALF Grooved	73 × 53 × 34 78 × 55 × 24	24 / 25

RICE STEAMER



RCS-12



RCS-24



MODEL	POWER	TRAY QUANTITY	CAPACITY (kg)	MACHINE SIZE PACKING SIZE (cm)	NET / GROSS WEIGHT (kg)
RCS-12	GAS	12 Trays	48	70 × 65 × 160 79 × 66 × 165	110 / 120
RCS-24	GAS	24 Trays	96	140 × 65 × 160 150 × 66 × 165	200 / 230

HOREKA EQUIPMENT

POPCORN MACHINE



POP-PO2



On/Off Switch



Heating Bowl



Cleaning Tray

MODEL	POWER (w)	OUTPUT (gr/minute)	MACHINE SIZE PACKING SIZE (cm)	NET / GROSS WEIGHT (kg)
POP-PO2	1350	220 / 2	55 × 41 × 75 60 × 48 × 79	17 / 19

CANDY FLOSS MACHINE



Easy to Remove



Heater



Storage

MODEL	TYPE	POWER (w)	OUTPUT (pcs/minute)	MACHINE SIZE PACKING SIZE (cm)	NET / GROSS WEIGHT (kg)
CDF-RM3	GAS	80	2	33 × 33 × 49 53 × 53 × 42	11 / 13
CDF-M3	Electric	1030	2	33 × 33 × 49 53 × 53 × 42	11 / 13

HEAVY DUTY BLENDER



On/Off Switch



Heavy Duty Blade



Handle Blander

MODEL	POWER (w)	CAPACITY (liter)	SPEED (rpm)	MACHINE SIZE PACKING SIZE (cm)	NET / GROSS WEIGHT (kg)
BLD-998	1600	2	30.000	19 × 22 × 49 31 × 26 × 38	3.5 / 4

MATERIAL
HANDLING



HAND PALLET

HPL SERIES



Lower Position
Pull up the fingertip for lowering



Neutral Position
Keep in the position to push & pull the truck



Lifting Position
Push down the fingertip for pump lifting



One-piece cast pump with reliable oil-proof hydraulic systems.



Reinforced for added strength of load capacity.



Effortless pallet entry/exit rollers to make it easier to push and pull pallet truck.



MODEL	HPL-3AC	HPL-5AC
CAPACITY (kg)	3000	5000
MIN. FORK HEIGHT (mm)	85	
MAX. FORK HEIGHT (mm)	195	
LIFTING HEIGHT (mm)	110	
FORK LENGTH (mm)	1220	
SINGLE FORK WIDTH (mm)	160	
WIDTH OVERALL FORKS (mm)	685	
FORK WHEEL-SINGLE (mm)	80 × 93	
FORK WHEEL-TANDEM (mm)	80 × 70	
STEERING WHEEL (mm)	180 × 50	
NET WEIGHT (kg)	92	

Steering

Easy to maneuver with 210 degrees turning radius. all pivots points are greased ensures excellent maneuverability with effortless steering.

Spray Finishing

Standard Painting system ensure the best power coating and painting quality.

Controlled Speed

Speed lowering valve can adjust the descent speed freely.

Reliable Construction

Heavy gauge steel construction, drop forged lift link arms provide available strength and durability.

Easy Lowering Operation

Foot and hand control the lowering function to ensure easy operation.

Overload Protection

Excellent and compact pump design with high-pressure relief valve to prevent overload.

HAND STACKER

HFL & HFE SERIES



HFL SERIES



HFL SERIES



HFE SERIES
SEMI AUTOMATIC

A SERIES



Adjustable forks to coordinate with different requirements.



Ergonomic rubber handle ensures a comfortable easy operation



Effortless and quick lifting for using foot pedal without loads.



Intergrated charger facilitates easy and reliable charging.



Safe packing in any situation with mechanical parking brake.

E SERIES



Comfortable handle to ensure easy pulling with long tiller



Safe parking in any situation

EW SERIES



Easy maneuverability and secure locking, economic and mobile work aid. Compact and space saving storage. Equipped with wheels in the mast also allows it to be used as trolley.



Precise lifting and lowering via hand lever.

MORE DETAIL



MODEL	HFL-1A	HFL-2A	HFL-1E	HFL-2E	HFL-14EW		HFE-120	HFE-130	HFE-225
LIFTING CAPACITY (kg)	1000	2000	1000	2000	1000	CAPACITY (kg)	1000	1000	2000
MAX. LIFT HEIGHT (mm)	1600		1600		1600	LIFTING HEIGHT (mm) FORK LENGTH (mm)	2000 1000	3000 1000	2500 1000
LOWERED HEIGHT OF FORKS (mm)	100		85		90	MIN.FORK HEIGHT (mm)	90		
FORK LENGTH (mm)	900		900		900	MOTOR POWER (w)	1600		
ADJUSTABLE WIDTH OF FORKS (mm)	240-680		320-740		300-1200	OUTER WIDTH OF LEGS (mm)	1400		
OUTER WIDTH OF FRONT LEGS (mm)	740		690		1400	INNER WIDTH OF LEGS (mm)	395		
FRONT WHEEL SIZE (mm)	100 × 50		75 × 70		75 × 70	ADJ. WIDTH OF FORKS (mm)	360 - 690		
REAR WHEEL SIZE (mm)	180 × 50		180 × 50		180 × 50	REAR WHEEL SIZE (cm) FRONT WHEEL SIZE (kg)	80 × 93 80 × 65		
SIZE (cm) WEIGHT (kg)	205×74×148 180		204×78×147 200		208×140×147 210	WEIGHT (mm)	305	350	350

JAKARTA



Jl. Pembangunan III No2C.
Petojo Utara. Jakarta Pusat 10130

HUNTING 021 623 20 700

jakarta@wiratech.co.id

SALES MESIN 0823 66 600 660
0823 66 600 800
0823 66 300 100
0823 66 600 100

SALES PLASTIK 0823 66 300 200
0823 66 300 100

INFO RESELLER 0823 6660 0606

SURABAYA



Jl. Bubutan No 79. Bubutan,
Kota Surabaya, Jawa Timur 60174

HUNTING 031 9924 3262

surabaya@wiratech.co.id

MOBILE 0822 6060 6365
0822 6060 6007
0822 6060 6303
0822 6060 6300

BANDUNG



Jl. Asia Afrika No.45. Alun-Alun,
Kota Bandung, Jawa Barat 40111

HUNTING 022 2053 2888

bandung@wiratech.co.id

MOBILE 0823 66 600 300
0823 66 600 080

SEMARANG



Jl. Pandanaran No.27. Randusari,
Semarang, Jawa Tengah 50244

HUNTING 024 7653 0555

semarang@wiratech.co.id

MOBILE 0823 66 100 111
0823 66 500 111

MAKASSAR



Jl. Sultan Alauddin No.246C,
Tamalate, Makassar.

HUNTING 0411 820 6620

makassar@wiratech.co.id

MOBILE 0823 66 888 881
0823 66 888 882

SERVICE CENTER & CUSTOMER CARE



JAKARTA

Pergudangan G198 Blok AI
Jl. Satu Maret No 15. Prepedan

CALL CENTER 0823 66 500 222
SPAREPART 0823 6650 3000
CS (wa only) 0823 66 300 300

SURABAYA

Jl. Bubutan No 79. Bubutan,
Kota Surabaya

CALL CENTER 0823 66 500 333